

דנמר אלקטרוניקה ובקרה בע"מ

רח' סחרוב 10 א.ת. ראשון לציון טלפון: 03 - 94 198 94 פקס: 03 - 94 198 95
נייד במשרד: 050-7513875 http://www.danmar.co.il מספרנו: 72004

CONTROL PANEL FACS-82

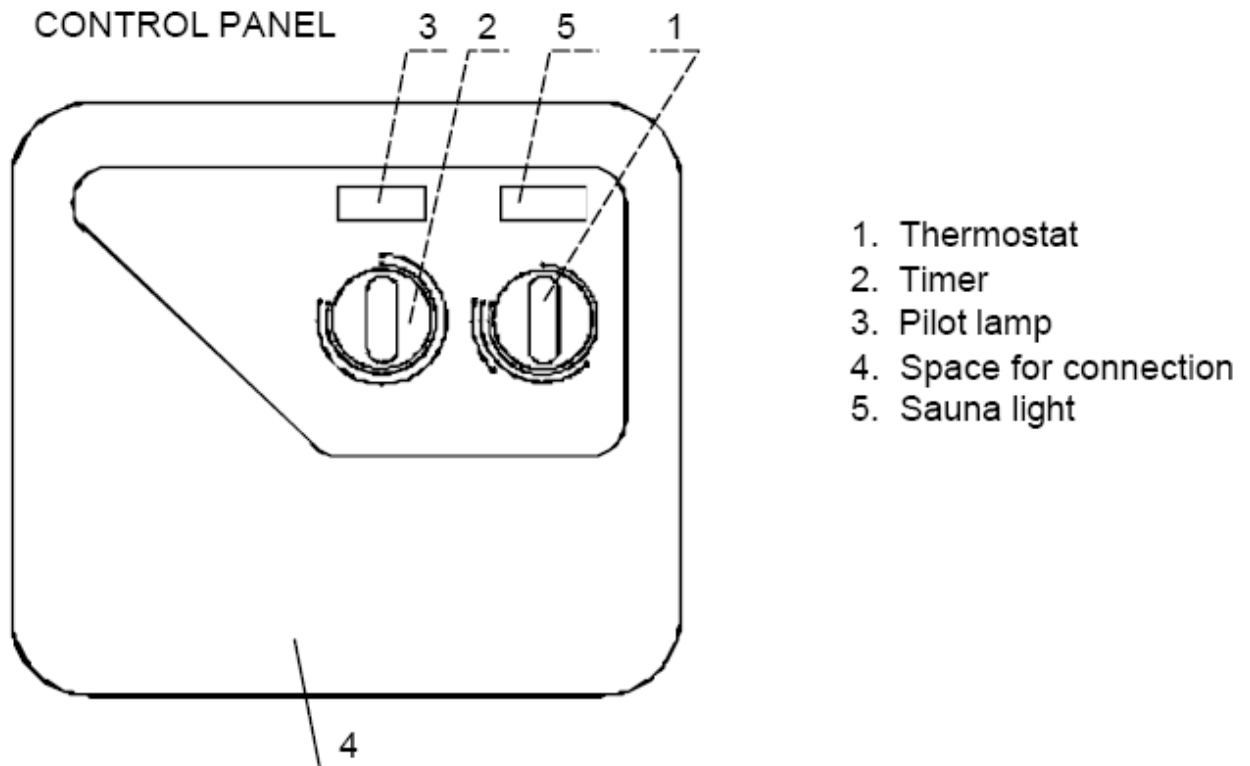

MOUNTING

The control panel is splash proof and may be mounted in the damp area adjacent to the cabin. The thermostat sensor must be wall mounted within the sauna. Please follow the measurements in the heater instructions to avoid the possibility of scorching the wood.

TIMER

The timer (2) is the main on/off switch for the controlpanel. To switch on, turn knob clockwise: The scale provides first a 1-4hr working band, then a 1-8hr preset band, which delays the switch on time. The pilot light (3) shows when the heater is on. When the sauna is finished, the timer knob may be turned back to the off position or left to switch off automatically at the end of the set working time.

REGULATION OF TEMPERATURE

The thermostat control (1) regulates temperature. Turn clockwise to achieve stepless increase of temperature level in the sauna. Resetting the thermostat each time the sauna is used is unnecessary.

When the position which maintains the desired temperature has been found, the knob may be permanently left at this setting.

LIGHT SWITCH

A rocker-switch (5) is provided for connections to the light fitting in the sauna.

SENSOR UNIT

The recommended mounting dimensions for the sensor are shown in the heater instructions. A 3 metre length of heat-resistant cable (170 C) 4 x 0,5mm - is provided. This may be extended with normal low voltage cable Outside the sauna cabin. Connection details for the sensor are shown in fig. 4.

LIMIT CONTROL

If the temperature in the sauna should rise too high (for example due to a thermostat fault) the limit switch in the sensor will turn off the power. When the fault has been rectified the switch may be reset.

- Sensor installation

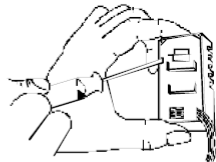

The sensor must be installed as shown in the illustration below. Digression from these instructions may cause overheating and risk for fire

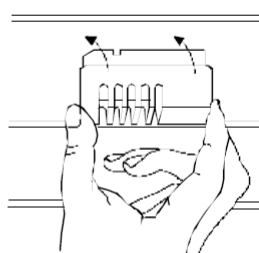
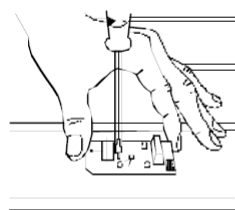
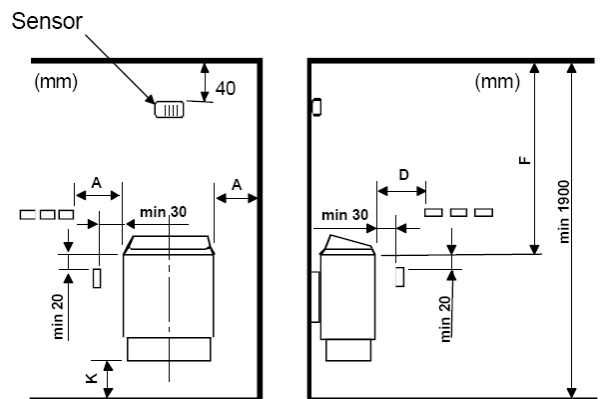

- Removing of the cover

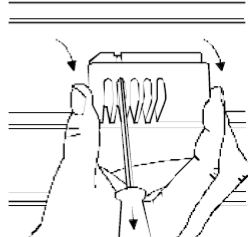
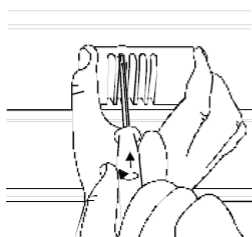

Heater kW	Distance (mm)		
	A	D	F
3,0	30	50	1200
4,5	50	80	1200
6,0	70	100	1250
8,0	100	150	1250
9,0	100	200	1250