

# humiSteam Wellness

umidificatori per bagni turchi  
humidifiers for steam baths

# CAREL



① **Manuale d'installazione**

Ⓒ **User manual**

→ **LEGGI E CONSERVA  
QUESTE ISTRUZIONI** ←  
**READ AND SAVE  
THESE INSTRUCTIONS**

**WARNINGS**

The CAREL S.p.A. humidifiers are advanced products, whose operation is specified in the technical documentation supplied with the product or can be downloaded, even prior to purchase, from the website [www.carel.com](http://www.carel.com). Each CAREL S.p.A. product, in relation to its advanced level of technology, requires setup/configuration/programming/commissioning to be able to operate in the best possible way for the specific application. The failure to complete such operations, which are required/indicated in the user manual, may cause the final product to malfunction; CAREL S.p.A. accepts no liability in such cases. The customer (manufacturer, developer or installer of the final equipment) accepts all liability and risk relating to the configuration of the product in order to reach the expected results in relation to the specific final installation and/or equipment. CAREL S.p.A. may, based on specific agreements, act as a consultant for the installation/commissioning/use of the unit, however in no case does it accept liability for the correct operation of the humidifier and the final installation if the warnings or suggestions provided in this manual or in other product technical documents are not heeded. In addition to observing the above warnings and suggestions, the following warnings must be heeded for the correct use of the product:

- **DANGER OF ELECTRIC SHOCK**

The humidifier contains live electrical components. Disconnect the mains power supply before accessing inside parts or during maintenance and installation.

- **DANGER OF WATER LEAKS**

The humidifier automatically and constantly fills/drains certain quantities of water. Malfunctions in the connections or in the humidifier may cause leaks.

- **DANGER OF BURNS**

The humidifier contains high temperature components and delivers steam at 100°C/ 212°F.

**Important:**

- The installation of the product must include an earth connection, using the special yellow-green terminal available in the humidifier.
- The environmental and power supply conditions must conform to the values specified on the product rating labels.
- The product is designed exclusively to humidify rooms either directly or through distribution systems (ducts).
- Only qualified personnel who are aware of the necessary precautions and able to perform the required operations correctly may install, operate or carry out technical service on the product.
- Only water with the characteristics indicated in this manual must be used for steam production.
- All operations on the product must be carried out according to the instructions provided in this manual and on the labels applied to the product. Any uses or modifications that are not authorised by the manufacturer are considered improper. CAREL S.p.A. declines all liability for any such unauthorised use.
- Do not attempt to open the humidifier in ways other than those specified in the manual.
- Observe the standards in force in the place where the humidifier is installed.
- Keep the humidifier out of the reach of children and animals.
- Do not install and use the product near objects that may be damaged when in contact with water (or condensate). CAREL S.p.A. declines all liability for direct or indirect damage following water leaks from the humidifier.
- Do not use corrosive chemicals, solvents or aggressive detergents to clean the inside and outside parts of the humidifier, unless specifically indicated in the user manual.
- Do not drop, hit or shake the humidifier, as the inside parts and the linings may be irreparably damaged.

CAREL S.p.A. adopts a policy of continual development. Consequently, CAREL reserves the right to make changes and improvements to any product described in this document without prior warning. The technical specifications shown in the manual may be changed without prior warning.

The liability of CAREL S.p.A. in relation to its products is specified in the CAREL S.p.A. general contract conditions, available on the website [www.carel.com](http://www.carel.com) and/or by specific agreements with customers; specifically, to the extent where allowed by applicable legislation, in no case will CAREL S.p.A., its employees or subsidiaries be liable for any lost earnings or sales, losses of data and information, costs of replacement goods or services, damage to things or people, downtime or any direct, indirect, incidental, actual, punitive,

exemplary, special or consequential damage of any kind whatsoever, whether contractual, extra-contractual or due to negligence, or any other liabilities deriving from the installation, use or impossibility to use the product, even if CAREL S.p.A. or its subsidiaries are warned of the possibility of such damage.

**DISPOSAL**

The humidifier is made up of metal parts and plastic parts. In reference to European Union directive 2002/96/EC issued on 27 January 2003 and the related national legislation, please note that:

1. WEEE cannot be disposed of as municipal waste and such waste must be collected and disposed of separately;
2. the public or private waste collection systems defined by local legislation must be used. In addition, the equipment can be returned to the distributor at the end of its working life when buying new equipment;
3. the equipment may contain hazardous substances: the improper use or incorrect disposal of such may have negative effects on human health and on the environment;
4. the symbol (crossed-out wheeled bin) shown on the product or on the packaging and on the instruction sheet indicates that the equipment has been introduced onto the market after 13 August 2005 and that it must be disposed of separately;
5. in the event of illegal disposal of electrical and electronic waste, the penalties are specified by local waste disposal legislation.

**Warranty on the materials:** 2 years (from the date of production, excluding consumables).

**Approval:** the quality and safety of CAREL S.P.A. products are guaranteed by the ISO 9001 certified design and production system, as well as by the  mark.



# Content

<b>1. INTRODUCTION AND ASSEMBLY</b>	<b>7</b>		
1.1 humiSteam Wellness (UEW*)	7		
1.2 Dimensions and weights	7		
1.3 Opening the packaging	7		
1.4 Positioning on the wall	7		
1.5 Wall-mounting	7		
1.6 Removing the front cover	8		
1.7 Fitting the front cover	8		
1.8 Components and accessories	9		
<b>2. WATER CONNECTIONS</b>	<b>10</b>		
2.1 Supply water	11		
2.2 Drain water	11		
<b>3. STEAM DISTRIBUTION</b>	<b>12</b>		
3.1 CAREL jet distributors (SDPOEM00**)	12		
3.2 CAREL linear distributors (DP***DR0)	12		
3.3 Steam hose	12		
3.4 Condensate drain hose	13		
<b>4. ELECTRICAL CONNECTIONS</b>	<b>14</b>		
4.1 Preparing the electric cableways	14		
4.2 Power cable connection	14		
4.3 Temperature probe connection (M2.1- M2.8)	14		
4.5 Alarm contact (M6.1 - M6.3)	15		
4.6 Utility connections (light, fans, sanitisation, essences)	15		
<b>5. REMOTE TERMINAL, GSM MODEM AND SUPERVISORY NETWORK</b>	<b>17</b>		
5.1 Remote display terminal	17		
5.2 GSM network connection (send SMS)	17		
5.3 Supervisory network (J19)	17		
<b>6. STARTING AND USER INTERFACE</b>	<b>18</b>		
6.1 Starting	18		
6.2 Stopping	18		
6.3 User interface	18		
6.4 Management menu	19		
<b>7. MAIN CONFIGURATIONS</b>	<b>21</b>		
7.1 Language	21		
7.2 Date and time	21		
7.3 Temperature probes	21		
7.4 Essences	21		
7.5 Time bands	22		
7.6 Fans	22		
7.7 Sanitisation	23		
7.8 Advanced settings (qualified personnel only)	23		
7.9 Copying the settings (backup)	24		
7.10 GSM (send SMS on alarms)	25		
7.11 Enable supervisor network	25		
7.12 Manual procedures (qualified personnel only)	25		
7.13 Displaying the alarms	26		
7.14 Info-menu	27		
7.15 Mechanically draining the water in the cylinder	27		
<b>8. MAINTENANCE AND SPARE PARTS</b>	<b>28</b>		
8.1 Spare parts for models UE001 to UE018	28		
8.2 Spare parts, models UE025 to UE065	30		
		8.3 Cleaning and maintenance of the cylinder	32
		8.4 Cylinder connection, three-phase models UE025 to UE065	32
		8.5 Cleaning and maintenance of the other components	32
		<b>9. WIRING DIAGRAMS</b>	<b>33</b>
		9.1 Diagram of single-phase models UE001 to UE009	33
		9.2 Diagram of three-phase models UE003 to UE018	34
		9.3 Diagram of three-phase models UE025 to UE065	35
		<b>10. CARATTERISTICHE GENERALI E MODELLI</b>	<b>36</b>
		10.1 humiSteam Wellness models and electrical specifications	36
		10.2 Technical specifications	37
		10.3 Models of steam hoses	37
		10.4 Models of concentrated jet steam distributors	38
		10.5 Models of linear distributors	38



# 1. INTRODUCTION AND ASSEMBLY

## 1.1 humiSteam Wellness (UEW\*)

Range of CAREL isothermal immersed electrode humidifiers with liquid crystal display for the control and distribution of steam in steam baths.

Models available (identifiable from the code shown on the product):

- UE001, UE003, UE005, UE008, UE009, UE010, UE015, UE018: smaller models with steam production capacity up to 18 kg/h, water connections under the base of the humidifier;
- UE025, UE035, UE045, UE065: larger models with steam production capacity from 25 to 65 kg/h, water connections on the side of the humidifier.

## 1.2 Dimensions and weights



Fig. 1.a

		UE001... UE008	UE009... UE018	UE025... UE045	UE045**... UE065
dimensions (mm)	A	365	365	545	635
	B	275	275	375	465
	C	620	712	815	890
weights (kg)	packaged	16	20	39	51
	empty	13.5	17	34	44
	installed*	19	27	60.5	94

Table 1.a

\*= in operating conditions filled with water;  
\*\*= 230 Vac model

## 1.3 Opening the packaging



- make sure the humidifier is intact upon delivery and immediately notify the transporter, in writing, of any damage that may be due to careless or improper transport;
- move the humidifier to the site of installation before removing from the packaging, grasping the neck only from underneath the base;
- open the cardboard box, remove the protective material and remove the humidifier, keeping it vertical at all times.

## 1.4 Positioning on the wall

- the unit is designed to be mounted on a wall that is strong enough to support the weight in normal operating conditions (see Wall-mounting below). Models UE025 to UE065 can stand on the floor;
- to ensure correct steam distribution, position the humidifier near the point of steam distribution;
- make sure the humidifier is level, allowing the minimum clearances (see Fig. 1.b) for maintenance operations.

**! Important:** during operation the metal casing heats up and the rear part resting against the wall may reach temperatures in excess of 60 °C.

### Distance from the walls

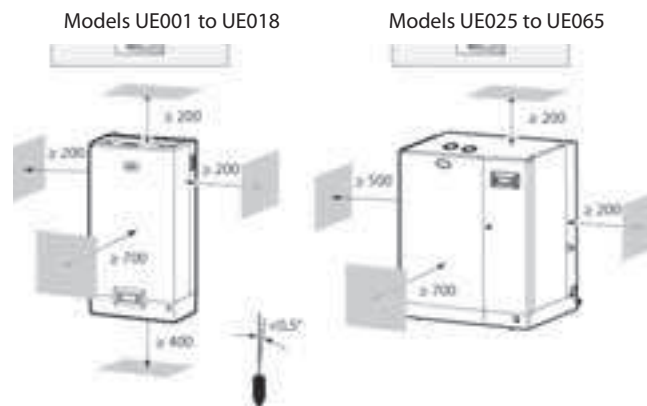

Fig. 1.b

## 1.5 Wall-mounting

Fit the humidifier on the wall using the support bracket and the screw kit supplied (for the dimensions in mm see Fig. 1.d).

Assembly instructions:

1. unscrew the wall bracket from the humidifier bracket;
2. fasten the wall bracket (see Fig. 1.c), checking horizontal position with a spirit level; if installed on a masonry wall, the plastic anchor plugs (dia. 8 mm) and screws (dia. 5 mm x L= 50 mm) supplied can be used;
3. hang the appliance to the bracket using the slot on the top edge of the rear of the appliance;
4. secure the appliance to the wall through the hole in the centre on the rear of the unit. For the weights and dimensions see Tab.1.a.

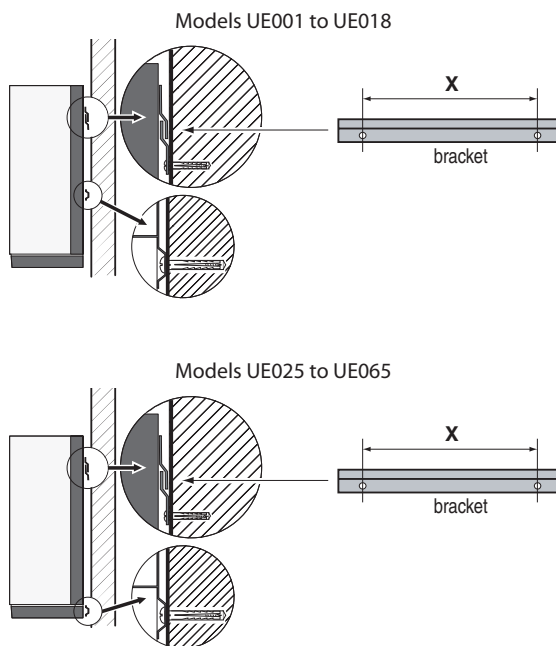

Fig. 1.c

Spacing of the holes on the wall  
Models UE001 to UE018      Models UE025 to UE065

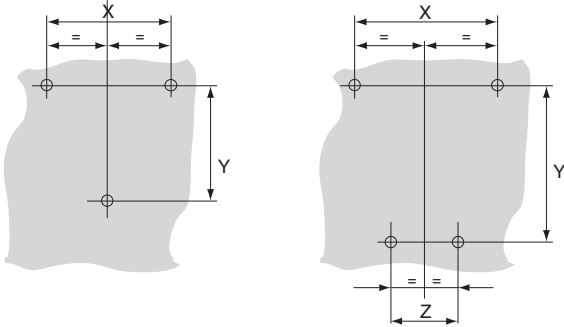

Fig. 1.d

distance (mm)	Models		
	UE001...UE018	UE025...UE045	UE045*...UE065
X	270	310	400
Y	360	655	730
Z	-	250	315

\* 230 Vac models only

### 1.6 Removing the front cover

Models UE001 to UE018:

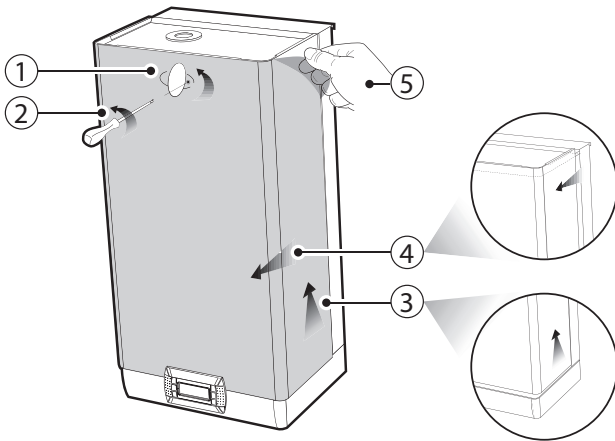

Fig. 1.e

1. turn oval-shaped label with the Carel logo, revealing the head of the earth screw below;
2. remove the screw using a screwdriver;
3. hold the cover by the sides and lift it around 200 mm, releasing it from the protruding edges of the humidifier;
4. remove the cover by moving it forwards;
5. remove the protective film.

Modelli UE025...UE065:

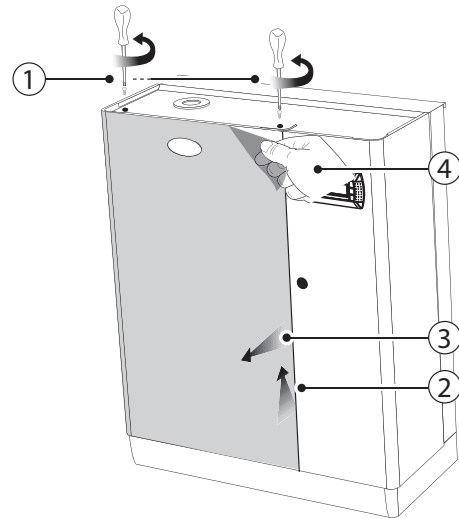

Fig. 1.f

1. remove the screws from the top of the humidifier using a screwdriver;
2. hold the cover from the top and lift it around 200 mm;
3. remove the cover by moving it forwards;
4. remove the protective film (from all the outside surfaces of the humidifier).

### 1.7 Fitting the front cover

Models UE001 to UE018:

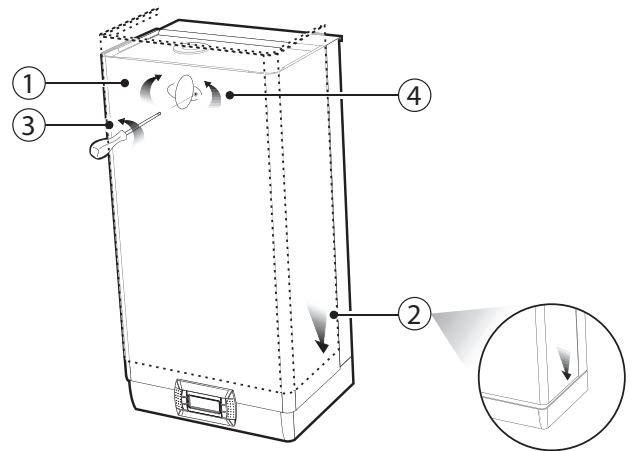

Fig. 1.g

1. turn the red oval-shaped plate with the CAREL logo, revealing the fastening hole below;
2. slip the cover onto the frame (keeping it slightly raised and tilted), until it rests on the rear edges;
3. tighten the earth screw using a screwdriver;
4. turn the red oval-shaped plate with the CAREL logo until covering the fastening holes.

Models UE025 to UE065:

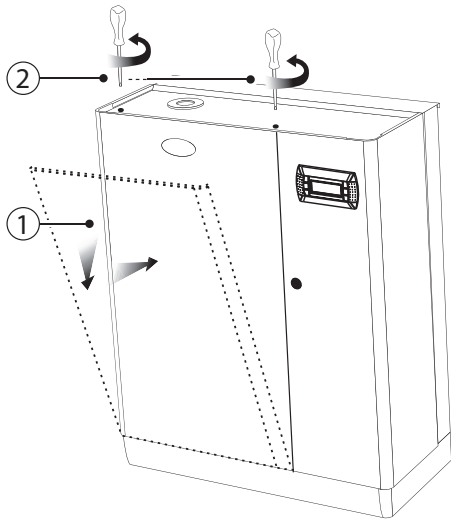

Fig. 1.h

1. slip the cover onto the frame (keeping it slightly raised and tilted), until it rests on the rear edges;
2. tighten the screws on the top of the humidifier using a screwdriver.

**! Important:** in models UE025 to UE065 open the electrical compartment on the humidifier using the lock with slot.

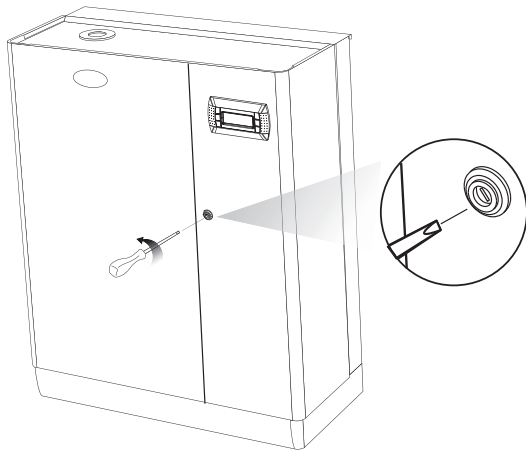

Fig. 1.i

### 1.8 Components and accessories

Once having opened the packaging and removed the front cover of the humidifier, make sure the following are included:



- kit of screws with plugs for wall-mounting;



- kit code 98C565P009 of connectors for the electronic board

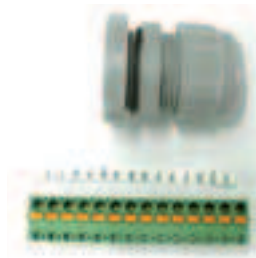

- kit code 98C565P012 of connector with label and cable gland for the connection of the utility cables (light, fans, essences and sanitisation pump)



- filter code 98C565P016 for fill solenoid valve



- kit code 98C565P018 of connectors for terminals with voltage-free contacts



- models UE025 to UE065 only: code FWHDCV0000 non-return valve with connection pipe



- UE025 to UE065 only: angular plastic hose (drain water connection).

## 2. WATER CONNECTIONS

**! Important:** before proceeding, disconnect the power supply.

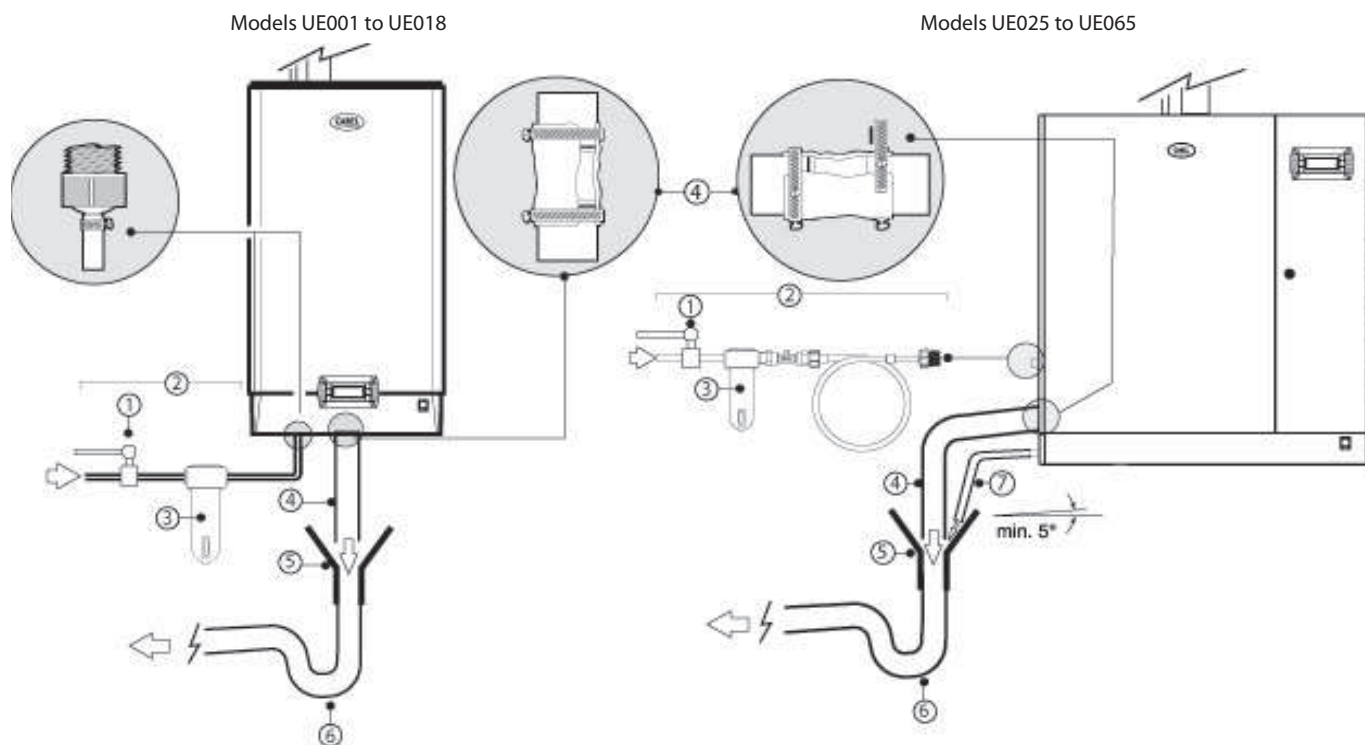

Fig. 2.a

### Water connections:



- 1. install a manual valve upstream of the installation (to be able to cut off the water supply);
- 2. connect the humidifier to the water supply, and fit the filter supplied (code 98C565P016) to the inlet of the fill solenoid valve.. On models UE001 to UE0018, use a hose with 3/4"G fittings (see par. "10.2 Technical specifications" page 37, compatible CAREL hose: code FWH3415000). On models UE025 to UE065 connect the hose with the non-return valve supplied (code FWHDCV0000) to prevent the water inside the humidifier from coming into contact with the mains water;
- 3. install a mechanical filter to trap any solid impurities (to be connected downstream of the tap);
- 4. connect a section of non-conductive pipe or hose for draining (resistant to temperatures of 100 °C and with a minimum inside diameter of 40 mm);
- 5. prepare a funnel to interrupt continuity in the drain line;

- 6. connect a drain trap to prevent the return of bad odours (minimum inside diameter 40 mm);
- 7. in models UE025 to UE065: connect a drain hose from the bottom tank of the humidifier (this can run into the drain funnel).

**! Important:** when installation is completed, flush the supply hose for around 30 minutes by piping water directly into the drain, without sending it into the humidifier. This will eliminate any scale or processing residues that may block the drain pump and cause foam when boiling.

### Fittings provided for the water connections:

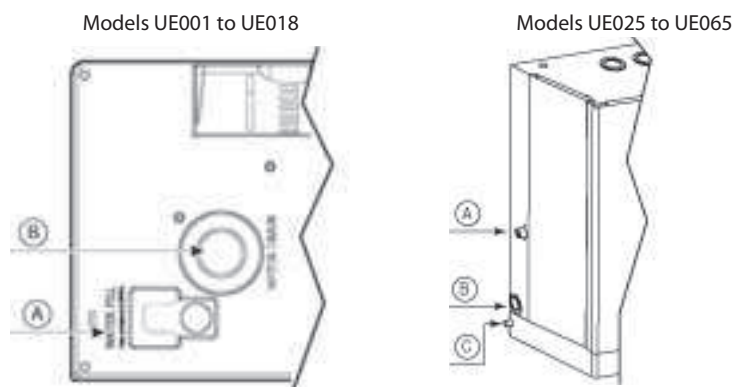

Fig. 2.b

#### Key:

- A. supply water inlet
- B. drain water outlet
- C. bottom tank drain water outlet (models UE025 to UE065 only)

## 2.1 Supply water

Only use mains water with:

- pressure between 0.1 and 0.8 MPa (1 and 8 bars), temperature between 1 and 40 °C and an instant flow-rate no lower than the rated flow of the fill solenoid valve, the connection is G3/4M (see par. "10.2 Technical specifications" page 37);
- hardness no greater than 40°fH (equal to 400 ppm of CaCO<sub>3</sub>), conductivity: 125 to 1250 µS/cm;
- no organic compounds.

supply water characteristics	unit of measure	normal water		water with low salt content	
		min.	max.	min.	max.
Hydrogen ions (pH)		7	8.5	7	8.5
Specific conductivity at 20°C ( $\sigma_{R,20^{\circ}C}$ )	µS/cm	350	1250	125	350
Total dissolved solids ( $C_R$ )	mg/l	( <sup>1)</sup> )	( <sup>1)</sup> )	( <sup>1)</sup> )	( <sup>1)</sup> )
Dry residue at 180°C ( $R_{180}$ )	mg/l	( <sup>1)</sup> )	( <sup>1)</sup> )	( <sup>1)</sup> )	( <sup>1)</sup> )
Total hardness (TH)	mg/l CaCO <sub>3</sub>	100 ( <sup>2)</sup> )	400	50 ( <sup>2)</sup> )	160
Temporary hardness	mg/l CaCO <sub>3</sub>	60 ( <sup>3)</sup> )	300	30 ( <sup>3)</sup> )	100
Iron + Manganese	mg/l Fe+Mn	=	0.2	=	0.2
Chlorides	ppm Cl	=	30	=	20
Silica	mg/l SiO <sub>2</sub>	=	20	=	20
Residual chlorine	mg/l Cl <sup>-</sup>	=	0.2	=	0.2
Calcium sulphate	mg/l CaSO <sub>4</sub>	=	100	=	60
Metallic impurities	mg/l	0	0	0	0
Solvents, thinners, detergents, lubricants	mg/l	0	0	0	0

Tab. 3.a

(<sup>1)</sup>)= values depend on the specific conductivity; in general:

$$C_R \cong 0.65 * \sigma_{R,20^{\circ}C}; R_{180} \cong 0.93 * \sigma_{R,20^{\circ}C}$$

(<sup>2)</sup>)= not less than 200% of the chloride content in mg/l CL<sup>-</sup>

(<sup>3)</sup>)= not less than 300% of the chloride content in mg/l CL<sup>-</sup>

There is not reliable relationship between hardness and conductivity of the water



### Important:

- do not treat the water with softeners, this may cause the entrainment of foam, affecting the operation of the unit;
- do not add disinfectants or anticorrosive compounds to the water, as these are potential irritants;
- the use of well water, industrial water or water from cooling circuits and, in general, any potentially chemically or bacteriologically contaminated water is not recommended.

## 2.2 Drain water

- this contains the same substances dissolved in the supply water, however in larger quantities;
- it may reach a temperature of 100 °C;
- it is not toxic and can be drained into the sewerage system.

## 3. STEAM DISTRIBUTION

For the correct delivery of steam, a steam distributor must be used, sized according to output of the humidifier.

In addition, the distributor must be installed in a part of the steam bath that is easily reached by the hoses running from the humidifier (see Fig. 3.a as an installation example).

### 3.1 CAREL jet distributors (SDPOEM00\*\*)

These can be fitted horizontally or vertically (hole facing upwards). See par. "10.4" page 38 for the models of distributors that are compatible with the humidifiers.

**Assembly instructions (see Fig.3.b):**

- make a series of holes on the wall according to the distributor drilling template;
- insert the distributor;
- fasten the flange using 4 screws.

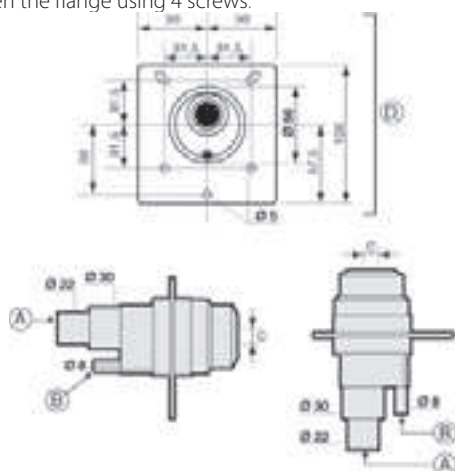

Fig. 3.b

**Key:**

- A. steam inlet
- B. condensate drain
- C. steam outlet

the dimensions of the hole vary depending on the models of distributor:

model SDPOEM0000: hole made manually, up to 30 mm in diameter);  
 model SDPOEM0012: diameter of the hole 12 mm;  
 model SDPOEM0022: diameter of the hole 22 mm.

- D. drilling template



**Note:** if steam hoses with an inside diameter of 30 mm are used, remove the 22 mm steam inlet section.

### 3.2 CAREL linear distributors (DP\*\*\*DR0)

These can be fitted horizontally. See par. "10.5" page 38 for the models of distributors that are compatible with the humidifiers.

**Assembly instructions (see Fig.3.c):**

- make a series of holes on the wall according to the distributor drilling template (included in the packaging with the distributor);
- insert the distributor with the steam holes facing upward;
- fasten the flange using 4 screws.

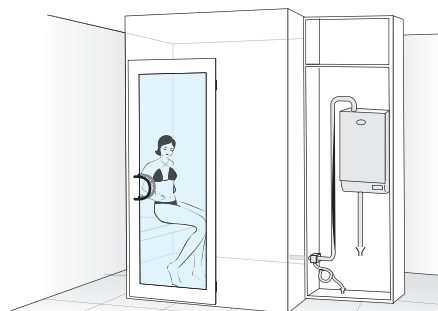

Fig. 3.a

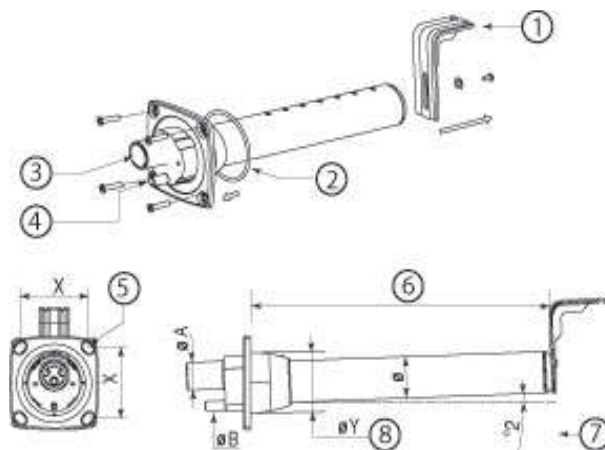

Fig. 3.c

**Key:**

- 1 "L"-shaped mounting support (where featured)
- 2 flange gasket
- 3 steam inlet (ØA)
- 4 condensate drain (ØB)
- 5 fastening screws (see the instruction sheet supplied with the distributor)
- 6 length (depending on the model of distributor, see par. "10.5" page 38)
- 7 angle (around 2°) for draining the condensate.
- 8 diameter of the hole on the wall (ØY)

**Dimensions in mm**

	CAREL linear distributors		
	DP***D22R0	DP***D30R0	DP***D40R0
ØA	22	30	40
ØB	10	10	10
ØY	58	68	89
Ø	35	45	60
X	68	77	99

Tab. 3.a



**Important:**

1. fit the distributor at a slight incline (at least 2°, to prevent the return of condensate);
2. the "L"-shaped mounting support (see part 1 Fig. 3.c) is supplied with steam distributor models from DP085\* to DP025\*. For shorter lengths, the support can be supplied as an option (code 18C478A088).

### 3.3 Steam hose

- use CAREL hoses (max. 4 m long, see par. "10.3" page 37). Rigid pipes may break and cause steam leaks;
- avoid the formation of pockets or traps (causes of condensate);
- avoid choking the hose due to tight bends or twisting.
- fasten the end of the hose to the connectors on the humidifier and the steam distributor using metal clamps, so that these do not detach due to the high temperature.

### 3.4 Condensate drain hose

During the operation of the humidifier some of the steam may condense, causing a decline in efficiency and noise (gurgling).

To drain the condensate, connect a drain hose with a drain trap and a minimum slope of 5° to the bottom of the humidifier (see Fig. 3.d). CAREL condensate drain hoses: code 1312353APG

**! Important:** the drain trap in the condensate drain hose the humidifier must be filled with water before starting.

Example of correct and incorrect installation of the steam hose and condensate drain hose:

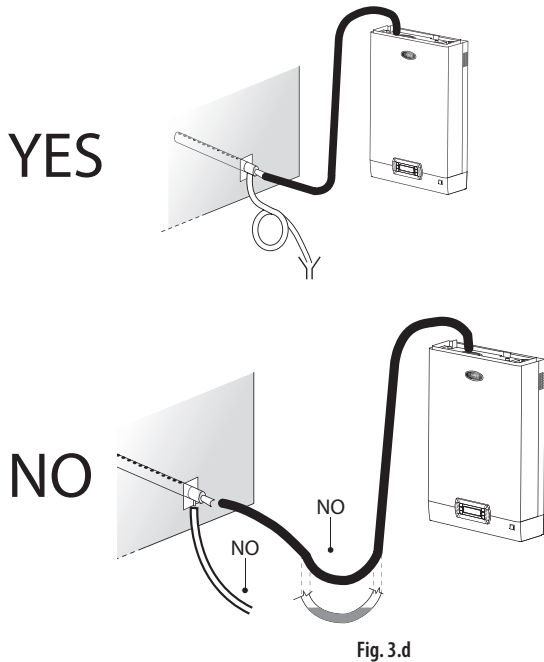

Fig. 3.d

#### Verifiche finali



- the steam outlet hoses run upwards and the distributor has a minimum incline of 2° upwards (see Fig. 3.c);
- the ends of the hose are tightened to the fittings with metal clamps;
- the curves in the tubing are sufficiently wide (radius > 300 mm) so as to not cause bending or choking;
- the steam hose has no pockets or traps for condensate to form;
- the paths of the steam and condensate hoses are as described in this chapter (see Fig. 3.d);
- the length of the steam hose is no greater than 4 metres;
- the incline of the steam hose is sufficient to allow correct draining of the condensate (> 20° for the upward sections, > 5° for the downward sections);
- the incline of the condensate hose is at least 5° at every point;
- the condensate hose always follows a downwards path and features a drain trap (filled with water before starting operation) to avoid steam being released.

## 4. ELECTRICAL CONNECTIONS

installer

user

service

### 4.1 Preparing the electric cableways

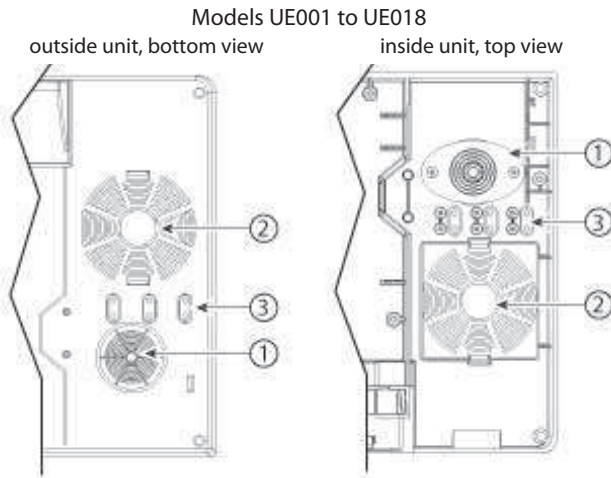

Fig. 4.a

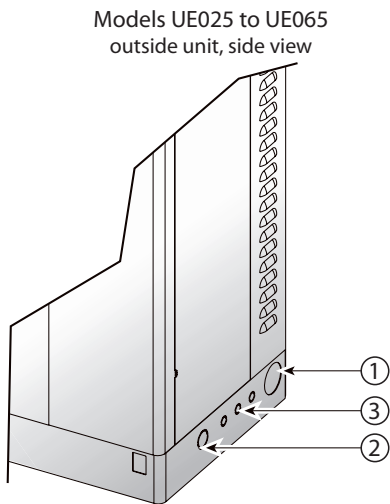

Fig. 4.b

Key to Figs. 4.a and 4.b:

1. power cable inlet;
2. utility cable inlet (after having drilled the plastic part): sanitisation pump, essences, fans, light.
3. probe cable inlet. On models UE001 to UE018, remove the plastic "tab" and use it to secure the cable (held in place by the screws provided).

### 4.2 Power cable connection

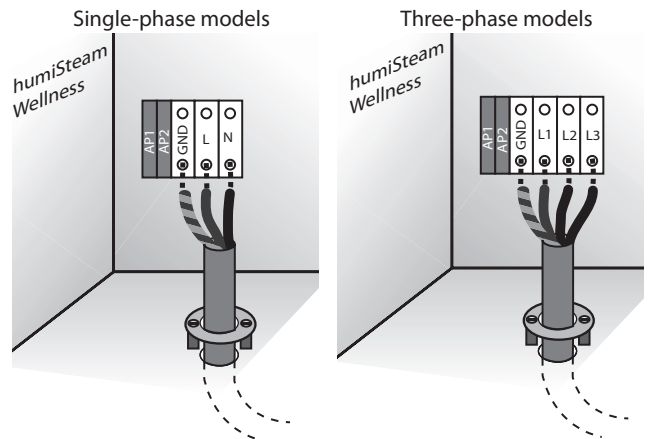

Fig. 4.c (view inside unit, electrical compartment)

**! Important:** connect the yellow-green cable to the earth point (GND).

### 4.3 Temperature probe connection (M2.1-M2.8)

- the humidifier can be connected to up to two probes for measuring and controlling the temperature inside the steam bath. The connection with two probes allows an "average" temperature reading (with the possibility to attribute a different "weight" to each probe, see par. "7.3 Temperature probes", page 21);
- active probes (voltage or current signal, CAREL code: ASET030001) or NTC probes (variable resistance) can be connected.

For connection, use the "eight pin" connection kit (supplied in the packaging) and run the cables out of the humidifier through the "cable opening" (Figs. 4.a or 4.b).

Active CAREL probe connections:

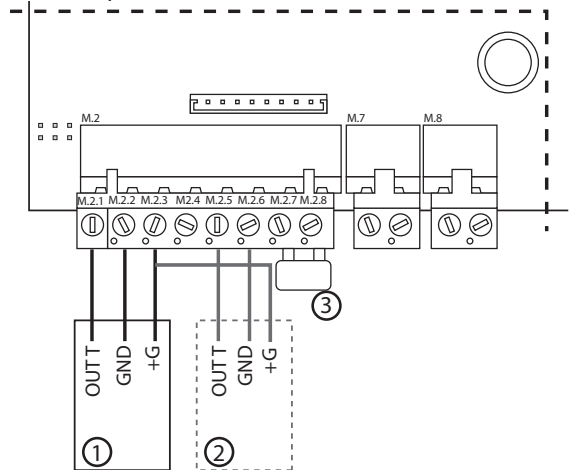

Fig. 4.d (detail of electronic board, humidifier electrical compartment)

CAREL NTC probe connections:

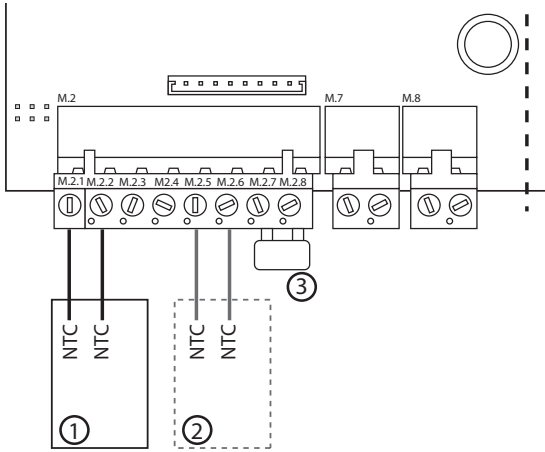

Fig. 4.e (detail of electronic board, humidifier electrical compartment)

Key to Figs. 4.d and 4.e:

- 1 probe CAREL 1
- 2 CAREL probe 2 (if available)
- 3 remote ON/OFF (contact closed= humidifier enabled; contact open= humidifier disabled, in standby)

If non-CAREL probes are used, check:

- voltage signal: 0 to 1 Vdc, 0 to 10 Vdc, 2 to 10 Vdc, terminal M2.1 (GND: M2.2);
  - current signal: 4 to 20, 0 to 20 mA, terminal M2.4 (GND: M2.6).
- In addition, depending on the type of power supply:
- +15 V, terminal M2.3;
  - + 1 Vdc 135 ohm, terminal M2.4.

Input probe configuration (pin strip connectors JS5, JS6)

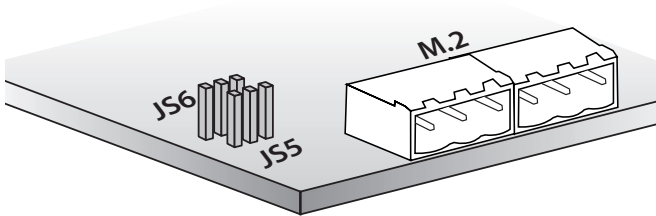

Fig. 4.f (detail of electronic board, in the humidifier electrical compartment)

pin strip	configuration	position	
		0 to 10 Vdc 2 to 10Vdc	0 to 1 Vdc, 4 to 20/0 to 20 mA, NTC probes
JS5	probe 1		 basic configuration
JS6	probe 2		 basic configuration

**Important:**

- to avoid unbalanced control, the earth of the probes or the external control devices must be connected to the earth of the appliance's controller.
- For the operation of the humidifier, M2.7 and M2.8 must be connected to the "remote ON/OFF" via an enabling contact or alternatively jumpered (default solution). If these terminals are not connected, all the internal and external devices managed by the controller will be disabled, with the exception of the drain pump for emptying the unit after extended periods.

**Note:** in industrial environments (IEC EN61000-6-2), the cables leaving the unit must not exceed 30 m in length, except for the room probe (terminals M2 pin 1-2-3-4-5-6), the remote on/off digital input (terminal M2 pin 7-8) and cable shields for RS485 communication.

### 4.5 Alarm contact (M6.1 - M6.3)

Contact available for the remote signalling of one or more alarms.

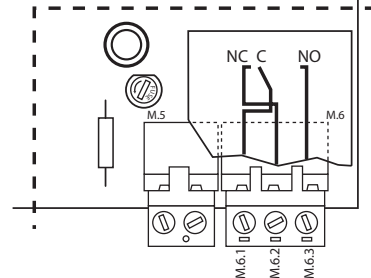

Fig. 4.g (detail of utilities board, humidifier electrical compartment)

**Electrical specifications:** 250 Vac; I<sub>max</sub>: 2 A resistive 2 A inductive.

**Note:** use clamps on the signal terminal blocks (alarm, utilities) to prevent the cables from being detached.

### 4.6 Utility connections (light, fans, sanitisation, essences)

The humidifier features of a terminal block for connecting the utilities, located under the electronic board (see the following figure for the connections).

Depending on the type of connection, the required voltage is made available for the outputs to the utilities (12 V, 24 V, 230 V or voltage-free contact).

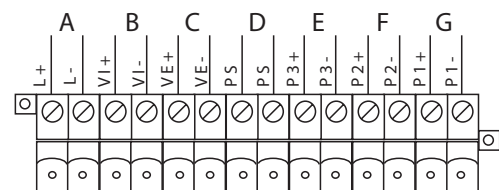

Fig. 4.h (detail of utilities board, humidifier electrical compartment)

**Legenda:**

- A light (L+ L-);
- B supply fan (VI+ VI-);
- C exhaust fan (VE+ VE-);
- D sanitisation pump (PS PS);
- E essence pump 3 (P3+ P3-);
- F essence pump 2 (P2+ P2-);
- G essence pump 1 (P1+ P1-).

## Types of utility connection

### ◆ “Utilities powered at the same voltage”

The humidifier supplies power to and activates the utilities connected at the same voltage. This is done by applying a 12 V, 24 V or 230 V power supply to terminals AP1 and AP2.

#### Procedure:

insert the terminal block supplied (code 98C565P012) into connector A and connect the utilities (see the following figure).



#### Note:

- maximum load for each utility: 2 A;
- AP1 and AP2 are protected by 6.3 A fuses.

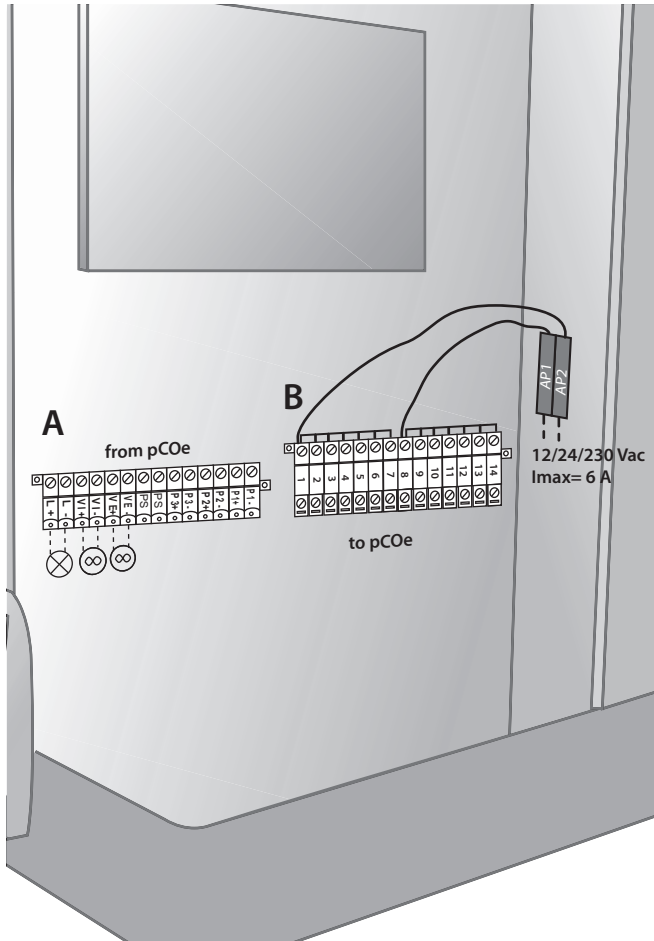

Fig. 4.i

### ◆ “Utilities powered at different voltages”

The humidifier activates but does not supply power to the utilities. The utilities are thus powered externally and at different voltages.

#### Procedure:

1. remove the terminal block (2 pieces) from connector B and disconnect the L, N cables;  
Insert the terminal block supplied (code 98C565P018) into connector B and reconnect the cables, L (terminal 1) & N (terminal 8);
2. jumper terminals AP1 and AP2;
3. insert the terminal block supplied (code 98C565P012) into connector A and connect the utilities (see the following figure).



#### Note:

- maximum load for each utility: 2 A;
- AP1 and AP2 are protected by 6.3 A fuses;
- the utilities must be suitably protected against overloads and short-circuits.

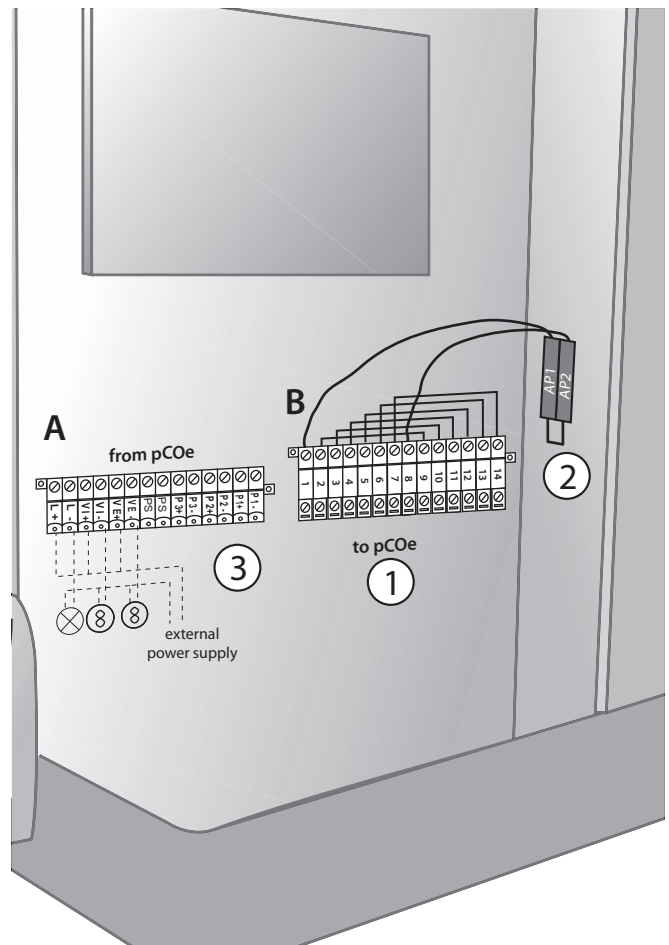

Fig. 4.j

## Final checks



- the rated voltage of the appliance corresponds to the rated supply voltage;
- the fuses installed are suitable for the line and the power supply voltage;
- a mains disconnect switch has been installed to disconnect power to the humidifier when required;
- the humidifier has been correctly earthed;
- the power cable is fastened using the tear-proof cable gland;
- terminals M2.7 and M2.8 are connected by jumper or connected to an enable-operation contact;
- if non-CAREL probes are used: the earth of the probes is electrically connected to the humidifier board earth;
- if the humidifier is controlled by an external control device, the earth of the signal is electrically connected to the controller earth.

## 5. REMOTE TERMINAL, GSM MODEM AND SUPERVISORY NETWORK

### 5.1 Remote display terminal

The display terminal can be detached from the humidifier and moved to another place.

Depending on the distance required, the following are necessary:

- up to 50 metres: 6-wire telephone cable and two ferrites (code 0907858AXX) (see Fig. 5.a);
- up to 200 metres: two CAREL TCONN6J000 boards, 6-wire telephone cables and an AWG20-22 shielded cable with 3 twisted pairs (for the connection of the two boards, Fig. 5.b).

**Note:** to fill the empty space left by the display terminal on the humidifier, use CAREL kit code HCTREW0000.

Remote connection of the terminal up to max 50 m

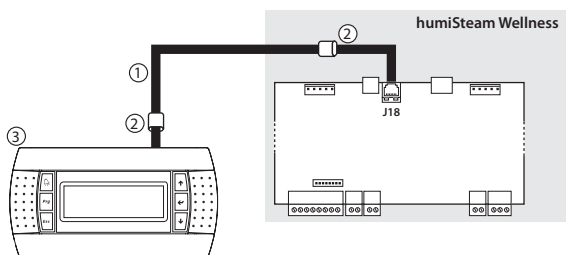

Fig. 5.a

Key:

- 1 telephone cable (up to 50 m distance);
- 2 two ferrites (code 0907858AXX) to be applied to the ends of the telephone cable;
- 3 remote display terminal.

Remote connection of the terminal up to 200 m

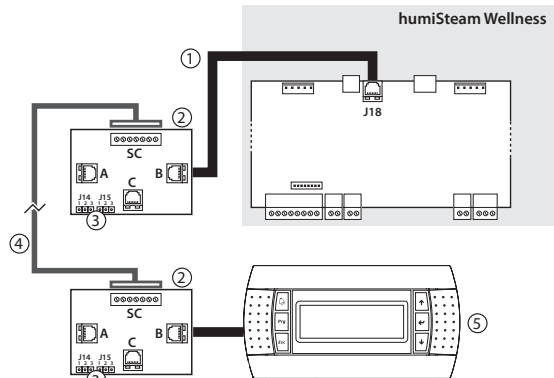

Fig. 5.b

Key:

- 1 telephone cable (up to 0.8 m distance);
- 2 CAREL TCONN6J000 board;
- 3 pin strip J14 and J15 in position 1-2 (power supply available on the telephone connectors A, B and C and screw SC);
- 4 AWG20-22 shielded cable with 3 twisted pairs to move the display terminal up to 200 m away. Connection to the TCONN6J00 board:

terminal SC	function
0	EARTH (shield)
1	+VRL
2	GND
3	RX/TX-
4	RX/TX+
5	GND
6	+VRL

- 5 remote display terminal

### 5.2 GSM network connection (send SMS)

The humidifier can be configured to send SMS message for alarms and malfunctions (see par. "7.10", page 25).

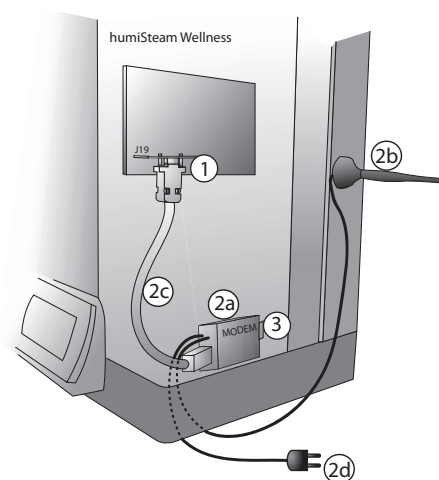

Fig. 5.c (inside humidifier, electrical compartment)

Key:

- 1 electronic board PCO100MDM0 (to be connected to connector J19 on the humidifier board)
- 2 CAREL GSM kit PLW0P65M00, made up of:
  - 2.a modem
  - 2.b antenna (with magnetic base)
  - 2.c serial cable
  - 2.d power supply
- 3 SIM card to be inserted in the modem. Make sure that the access password (PIN number) is not enabled

### 5.3 Supervisory network (J19)

The humidifier can be connected to the following optional boards:

- PCOS004850 for CAREL connections;
- PCOS004850 for Modbus® connections;
- PCO10000F0 for Lon connections;
- PCO100MDM0 for RS232 connections;
- PCOS004850 for Winload connections.

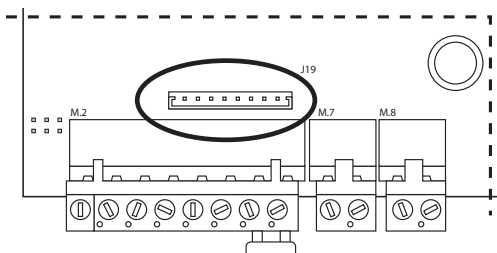

Fig. 5.d (detail of the electronic board, humidifier electrical compartment)

**Important:** for the tLAN and pLAN connections in residential household (IEC EN 55014-1) and residential (IEC EN 61000-6-3) environments, use shielded cable (with shield connected to GND). This warning also applies to the cables leaving the unit.

## 6. STARTING AND USER INTERFACE

Before starting the humidifier, check:



- water connections: Fig. 2.a page 10. In the event of water leaks do not start the humidifier before having resolved the problem;
- steam distribution: Fig. 3.d page 13;
- electrical connections chap. "4" page 14.

### 6.1 Starting

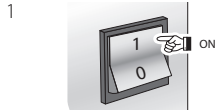

- 1
- 2 if the cylinder is new, run a pre-wash cycle (the cylinder is filled and emptied three times, cleaning the inside walls from impurities, see par. "7.12" page 25).

### 6.2 Stopping

- 1 empty the water in the cylinder to avoid stagnation (manual drain by "ON/OFF quick access" screen, see the following page, or par. "7.15" page 27);

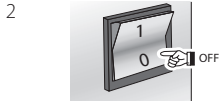

### 6.3 User interface

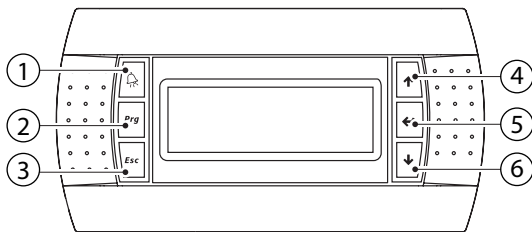

Fig. 6.a

Key to the keypad:

button	function
1	alarm list active alarms
2	PRG access the "Management menu" screen (password = 77)
3	ESC return to "Simple" or "Main" screen
4	UP increase the set point
5	ENTER from "Main" screen: open "ON/OFF quick access" screen from "Simple" screen: select type of essence ENTER and PRG: move from "Simple" to "Main" screen (and vice-versa).
6	DOWN decrease the set point

The humidifier produces steam when the temperature recorded (displayed in the centre of the screen in large characters) is less than the set point (at the top in smaller characters).

Set point: maximum temperature threshold above which the humidifier no longer produces steam (can be changed using the UP and DOWN buttons).

To display the temperature inside the steam bath and the set point, two types of screens are available:

"Simple": with the possibility to modify the set point and the type of essences;

"Main": with the possibility to modify the set point, the type of essences and access the "ON/OFF quick access" and "Management menu" screens.

#### "Simple" screen

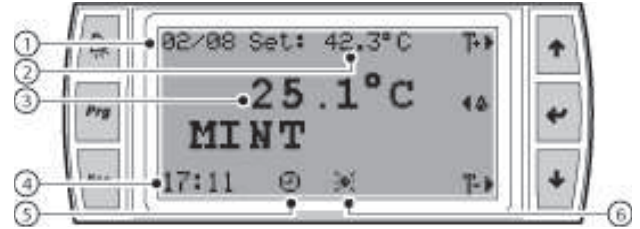

Fig. 6.b

Key:

symbol	function
1	day and month
2	set point temperature (can be modified using the UP or DOWN button)
3	temperature inside the steam bath (measured by the probe/probes)
4	hour and minutes
5	time bands set (when flashing indicates that a time band is in progress)
6	light on inside the steam bath
Essence (e.g. Mint)	essence enabled (delivered when the humidifier produces steam)

#### "Main" screen

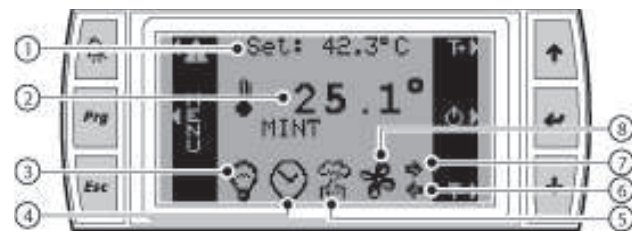

Fig. 6.c

Key:

symbol	function
1	set point temperature (can be modified using the UP or DOWN button)
2	temperature inside the steam bath (measured by the probe/probes)
3	light on inside the steam bath
4	time bands set (when flashing indicates that a time band is in progress)
5	steam production (without "cloud" steam production in standby)
6	supply fan (fan 1) on
7	exhaust fan (fan 2) on to
8	when moving indicates the operation of the fans, when still indicates fans enabled but in standby
Essence (e.g. Mint)	essence enabled (delivered when the humidifier produces steam)

The following screens can be accessed from the "Main" screen:

- ENTER button: "ON/OFF quick access"
- PRG button: "Configuration menu".

“ON/OFF quick access” screen



Fig. 6.d

Used to:

- enable steam production (ON) and activate the manual drain function (\*);
- select the type of essence (1, 2, 3);
- enable the sanitisation function (ON);
- switch on the light (ON).

Function buttons:

- ENTER: move the cursor inside the screen;
- UP or DOWN: enable/disable.

(\*) Manually drain the water in the cylinder:

- access the “ON/OFF quick access” screen,
- position the cursor on “steam”;
- press the UP and DOWN buttons together for a few seconds.

The same procedure can be repeated to stop the drain cycle in progress.

**! Important:**

- the “ON/OFF quick access” screen only displays the functions enabled in configuration phase.
- with steam production disabled (OFF) the supply and exhaust fans can be enabled manually;
- if the humidifier is enabled but not producing steam, check the following possible causes:

possible cause	solution
the temperature of the steam bath is higher than the set point	wait for the temperature of the bath to fall below the set point
alarms are active that stop steam production (ALARM button flashing).	check and resolve the error (see par. “7.13” page 26)
The humidifier is set to “manual”	deactivate the manual procedure (submenu par. “7.12”, see page 25)
time bands are active (CLOCK icon flashing on the display);	disable the time band (see par. “7.5” page 22), or modify as required.

Tab. 6.a

“Alarms” screen



Fig. 6.e

Indicates an alarm is active, press to display.

“Management menu” screen



Fig. 6.f

To access press:

- PRG from the “Main” screen;
- ENTER to move the cursor to the “0”;
- UP or DOWN to enter the password “77”;
- ENTER to confirm and enter the management submenu:
  1. **User;**
  2. **Essence;**
  3. **Fan management;**
  4. **Maintenance (info, software, hardware);**
  5. **Sanitisation;**
  6. **Alarm log;**
  7. **Network;**
  8. **GSM.**

The management menu, the submenu and the screens are cyclical, and follow the same path also in the opposite direction.

## 6.4 Management menu

installer	1 User	Clock	
		Scheduler	
		Schedule (*)	
		Week sch. (*)	
		T. setpoint (*)	
	Enable descriptions (i)		
	2 Essences	Essence 1 (*)	
		Essence 2 (*)	
		Essence 3 (*)	
	3 Fans	Supply fan (*)	
Exhaust fan (*)			
user	4 Maintenance	1 Maint info	SW outputs (**)
			Nom. values (**)
			Cylinder status (**)
			Sys info (**)
		2 Maint SW	Additional features
			Additional features
			Disable emptying
			Conductivity threshold
			Control parameters
			SW Input/output
			Backup
		Recovery	
	3 Maint HW	Setup	
		Essences	
		Essences	
		Fans	
		Temperature probe 1	
		Temperature probe 2	
		Other options	
		Man. procedure	
		Manual proc.	
		Manual procedure	
	5 Sanitisation	San. (*)	
		San. Phase 1 (*)	
		San. Phase 2 (*)	
	6 Alarm log	Log (**)	
	7 Network	Supervision	
8 GSM (*)	SMS 1 (*)		
	SMS 2 (*) (**)		

Tab. 6.b

(\*) screens available if the functions (user, essences, fans, maintenance, sanitisation, network, GSM) have been enabled. For example: the screens in the “fans” submenu are only visible if enabled in the “Maint HW” submenu;

(\*\*) read-only values.

### Function of the keypad in the management menu

button	function
alarm	access the alarm screen, displaying any alarms in progress (the button flashes)(*)
PRG	from the “Main” screen: access the management menu
ESC	return to the previous screen(**)
UP e DOWN	<ul style="list-style-type: none"> <li>in the “management menu”: navigate the submenus, screens, parameters cyclically (also in the opposite direction)</li> <li>inside a screen: modify the values of the parameters (YES/NO, ON/OFF, temperature range,...)</li> </ul>
ENTER	<ul style="list-style-type: none"> <li>select a submenu, screen, parameter</li> <li>save the changes to the parameters and move the cursor to the next parameter</li> </ul>

(\*) To reset an alarm in progress, press the ALARM button again.

(\*\*) Important: before pressing the ESC button, press the ENTER button to save the last change made.

### Installer’s notes

Names chosen for the essences

Essence 1: .....

Essence 2: .....

Essence 3: .....

## 7. MAIN CONFIGURATIONS

### 7.1 Language

The display terminal can be configured in: Italian, French, Spanish, English, German.

To change the language, from the "Main" screen press:

- PRG;
- ENTER;
- UP or DOWN to enter the password "77";
- ENTER;
- DOWN (3 times) until displaying the "Maintenance" submenu;
- ENTER;
- DOWN (once) until displaying the "Maint SW" submenu;
- ENTER;
- DOWN (5 times) until displaying "SW Input/output" screen;
- ENTER (twice) to move the cursor to the parameter "language";
- UP or DOWN to change the language;
- ENTER to confirm the language selected and return to the "Main" screen

 **Note:** in the "SW Input/output" screen, the unit of measure can also be selected, °C-kg/h (default) or °F-lbs/hr.

### 7.2 Date and time

To set the date and time, access the "User" submenu and press:

- ENTER to display the "clock" screen;
- ENTER to move the cursor to the first digit of the hour;
- UP or DOWN to modify the first digit of the hour;
- ENTER confirm and move the cursor to the second digit of the hour;
- continue with the UP/DOWN buttons and ENTER to set the minutes, day (number), month, year, weekday (from Monday to Sunday);

### 7.3 Temperature probes

The humidifier can manage up to two temperature probes:

- with one probe, the value read is shown directly on the display;
- with two probes, the values saved are "averaged" by the humidifier, and the result is shown on the display (\*\*).
- The "Temperature probe" screen ("Maint HW" submenu) can be accessed to set the relevance of one probe compared the other in percentage terms ("weigh probes" parameter). In addition, for each probe the minimum and maximum of the scale and the offset can be set.

#### Probe settings

From the "Maint HW" submenu press:

- |         |  |
|---------|--|
| probe 1 | <ul style="list-style-type: none"> <li>• ENTER to confirm</li> <li>• DOWN to reach the "Temperature probe 1" screen</li> <li>• ENTER to confirm and move the cursor to the "type of probe" parameter</li> <li>• UP or DOWN to select the type of probe (*)</li> </ul>  |
| probe 2 | <ul style="list-style-type: none"> <li>• ENTER to save and move the cursor to "enable probe 2";</li> <li>• UP or DOWN to enable the second probe (YES);</li> <li>• ENTER to move the cursor to "weigh probes" (**) (UP and DOWN to modify the weights of the 2 probes and ENTER to save and move the cursor);</li> <li>• ENTER to return to the start of the screen;</li> <li>• DOWN to access the screen "Temperature probe 1";</li> <li>• ENTER to move the cursor to the min. and max. scale and offset values (UP and DOWN to modify the value and ENTER to save and move the cursor);</li> <li>• ESC until displaying the "Main" screen.</li> </ul> |

(\*) Possible probe configurations: NTC, 0 to 1 V, 2 to 10 V, 0 to 10 V, 0 to 20 mA, 4 to 20 mA, 0 to 135 ohm, 135 to 1000 ohm

(\*\*) to achieve a temperature value measured with two probes, the humidifier carries out the following calculation:

$$T_m = (T_{s1} * W_1 / 100) + (T_{s2} * W_2 / 100)$$

T<sub>m</sub> = temperature shown on the display

T<sub>s1</sub> & T<sub>s2</sub> = temperatures read by the two probes

W<sub>1</sub> & W<sub>2</sub> = weights attributed to the two probes, percentage value (W<sub>1</sub>+W<sub>2</sub>=100)

For example, with the following values:

T<sub>s1</sub> = 42° W<sub>1</sub> = 60%

T<sub>s2</sub> = 44° W<sub>2</sub> = 40%

$$T_m = (42 * 60 / 100) + (44 * 40 / 100) = 42.8 °C$$

### 7.4 Essences

The essences are delivered into the steam bath when the humidifier is producing steam and the temperature reaches 70% of the set point.

For example: if the set point is 50°C, the essence will be delivered when the humidifier is producing steam and the temperature measured exceeds 35°C.



**Important:** make sure that the external essence pump is correctly connected.

#### Enabling the essences

From the "Maint HW" submenu press:

- ENTER to confirm;
- DOWN to select the "Essences" screen (essences 1 and 2);
- ENTER to confirm;
- UP or DOWN to enable (YES) essence 1;
- ENTER to confirm;
- UP or DOWN to enable (YES) essence 2;
- ENTER to confirm;
- DOWN to select the "Essences" screen (essence 3);
- ENTER to confirm;
- UP or DOWN to enable (YES) output essence 3;
- ENTER to confirm;
- ESC twice to return to the management menu.

#### Setting the essence operating times

From the "Essences" submenu press:

- ENTER to select the "Essence 1" screen;
- ENTER to confirm and move the cursor to the "Time ON" parameter;
- UP or DOWN to modify the ON seconds for essence 1;
- ENTER to confirm and move the cursor to the "Time OFF" parameter;
- UP or DOWN to modify the OFF seconds for essence 1;
- ENTER to confirm and move the cursor to the "name" parameter;
- UP or DOWN to modify the name of the essence, e.g.: Menthol (\*);
- repeat the same procedure (ON, OFF times and essence name) for the other essences enabled;
- at the end press ESC repeatedly to return to the "Main" screen.

(\*) Characters and symbols available for naming the essences:

A	B	C	D	E	F	G	H	I	J	K	L
M	N	O	P	Q	R	S	T	U	V	W	X
Y	Z	0	1	2	3	4	5	6	7	8	9
+	-	*	:	;	,	(	)	/	#		

Function buttons:

- UP or DOWN to modify the characters;
- ENTER to save and move the cursor to the next character. Up to 10 characters can be used.

Write the names of the essences in the "Installer's notes" on page 20.

Up to until three essences can be set, and selected from the "ON/OFF quick access" screen or the "Simple" screen. The display will show the name or number of the chosen essence.

## 7.5 Time bands

These are used to switch the humidifier on/off and change the set point at set times.

Two types of time bands are available:

1. Daily bands ("ON/OFF scheduler" parameters): set how many times to start/stop steam production over a period of 24h:

- 2 daily operating periods (parameters P1-1 and P1-2)

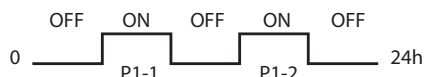

- 1 daily operating period (parameter P2)

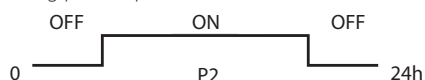

- Humidifier enabled all day (parameter P3)

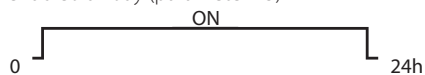

- Humidifier disabled all day (parameter P4)

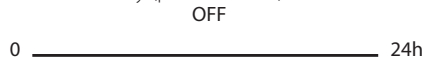

The operating mode (P1, P2, P3, P4) can be associated with each day of the week (from Monday to Sunday).

2. "Variable set point" bands ("Temp. scheduler" parameters): four different temperature set points that vary throughout the day (parameters Z1, Z2, Z3, Z4).

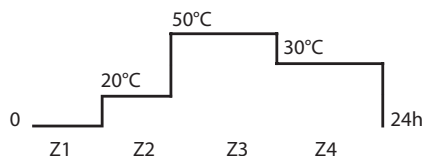

The "daily" and "variable set point" time bands can be programmed to set steam production according to the requirements of the operator of the steam bath (e.g. based on closing times) and with a customised temperature trend (using the 4 set point threshold).



### Note:

- during the time band without operation ("OFF"), the humidifier is NOT actually off, but rather steam production is temporarily disabled, including manually;
- the "daily" time bands have priority over the "variable set point". For example, setting P4 on Monday (steam bath closed), parameters Z1, Z2, Z3, Z4 (different set point values) will be ignored, because the humidifier is not programmed to operate on that day.

### Setting the daily bands ("ON/OFF scheduler"):

From the "User" submenu press:

- ENTER to confirm;
- DOWN until displaying the "Scheduler" screen;
- ENTER to confirm and move the cursor to the "ON/OFF scheduler" parameter;
- UP or DOWN to enable (YES) the daily bands;
- ENTER (twice) to return to the start of the screen;
- DOWN to access the "Scheduler" screen: to set the daily band start and end time (P1-1, P1-2 and P2). Use: ENTER to move the cursor and UP or DOWN to modify the value;

- ENTER until move the cursor to the start of the screen;
- DOWN to access the following screen, "Week sch.": this screen can be used to assign the type of time band (P1, P2, P3, P4) to each day of the week. Use ENTER to move the cursor and UP or DOWN to modify the value;
- ESC repeatedly to return to the "Main" screen.

The display shows the  symbol (that flashes when the time bands are active).

### Setting the variable set point bands ("Temp. scheduler"):

From the "User" submenu press:

- ENTER to confirm;
- DOWN until accessing the "Scheduler" screen;
- ENTER (twice) to confirm and move the cursor to "Temp. scheduler";
- UP or DOWN to enable (YES) the "Temp. scheduler" parameter;
- ENTER to return to the start of the screen;
- DOWN until accessing the "T. setpoint" screen: this screen can be used to customise up to four set point values per day (Z1, Z2, Z3, Z4). Use ENTER to move the cursor and UP or DOWN to modify the value;
- ESC repeatedly to return to the "Main" screen.

The display shows the  symbol (that flashes when the time bands are active).

## 7.6 Fans

The use of the supply and exhaust fans:

- guarantee air change;
- perform the sanitisation cycles;
- create the "mist effect".

### Enabling the fans

From the "Maint HW" submenu press:

- DOWN until accessing the "Fans" screen
- ENTER to move the cursor to "supply fan"
- UP or DOWN to enable (YES) the supply fan
- ENTER to move the cursor to exhaust fan
- UP or DOWN to enable (YES) the exhaust fan
- ESC repeatedly to return to the "Main" screen

The display shows the  symbol (next to  if the fans are on).

### Manual fan mode

The manual management of the fans, from the "ON/OFF quick access" screen, is only available if steam production is disabled (OFF). The manual activation of the fans during steam production is exclusively controlled from the management menu.

In this way, the fans can be started using the "ON/OFF quick access" screen (ENTER from the "Main" screen), stopping steam production (steam OFF). When steam production is ON they will be stopped automatically.

To switch the fans on and off using the management menu (steam ON), from the "Fans" submenu press:

- ENTER to confirm and access the Supply fan and/or Exhaust fan screen (depending on the fan enabled);
- ENTER to move the cursor to Mode (manual/automatic);
- UP or DOWN to set "Manual";
- ENTER to move the cursor to Production (ON/OFF);
- UP or DOWN to set "ON";
- ENTER to confirm;
- UP or DOWN to repeat the same operation for the other fan (if enabled);
- ESC repeatedly to return to the "Main" screen

The operation of the fans is bound by steam production: this is switched on and off only from the management menu (setting production "OFF" on the fans screen).

#### Automatic fan mode

This varies depending on the type of fan:

- supply fan: the fan stops when reaching the set point (related to steam production);
- exhaust fan: the fan starts when reaching the set point, or alternatively after a set time (periodical operation, independent of steam production).

#### Automatic supply fan mode

From the "Fans" submenu press:

- ENTER to confirm and access the "Supply fan" screen;
- ENTER to move the cursor to "Mode" (manual/automatic);
- UP or DOWN to set "Automatic";
- ENTER to confirm;
- ESC repeatedly to return to the "Main" screen.

The fan runs until reaching the temperature set point (related to steam production).

#### Automatic exhaust fan mode

From the "Fans" submenu press:

- ENTER to confirm and DOWN to access the Exhaust fan screen;
- ENTER to move the cursor to "Mode" (manual/automatic);
- UP or DOWN to set "Automatic";
- ENTER to confirm and move the cursor to "type";
- UP or DOWN to choose the automatic "Setpoint/Periodic"(\*) mode;
- ESC repeatedly to return to the "Main" screen.

(\*) Setpoint: The fan starts when reaching the temperature set point and steam production stops.

Periodic: The fan starts and stops after a certain operating time (in the "Exhaust fan" screen, set ON time and OFF time). This mode is not related to steam production or the set point.

To switch the fans on and off using the "ON/OFF quick access" screen (steam OFF), from the "Fans" submenu press:

- ENTER to confirm and access the Supply fan and/or Exhaust fan screen (depending on the fan enabled);
- ENTER to move the cursor to "Mode" (manual/automatic);
- UP or DOWN to set "Manual";
- ENTER to move the cursor to Production (ON/OFF);
- UP or DOWN to set "OFF";
- ENTER to confirm;
- UP or DOWN to repeat the same operation for the other fan (if enabled);
- ESC repeatedly to return to the "Main" screen.

## 7.7 Sanitisation

The sanitisation cycle is used to alternately activate the two fans:

- phase T1 supply fan;
- phase T2 exhaust fan.

During the operation of the fans, steam production and the sanitisation pump can be activated (to deliver the disinfecting liquid).

The activation of the sanitisation cycle can be manual (using the "ON/OFF quick access" screen) or automatic (at the end of the last steam production time band).



**Note:** Automatic mode is only available when the time bands are enabled.



**Important:** before setting the sanitisation cycle, make sure that the external pump/solenoid valve - used to inject the disinfectant in the steam hose - is connected correctly.

#### Enabling sanitisation

From the "Maintenance" submenu press:

- ENTER to confirm;
- DOWN to select the "Maint HW" menu;
- ENTER to confirm;
- DOWN until selecting the "Other options" screen;
- ENTER to confirm and move the cursor to "enable saniticat";
- UP or DOWN to enable (YES);
- ENTER to confirm;
- ESC repeatedly to return to the "Main" screen.

#### Manual sanitisation mode

From the "sanification" submenu press:

- ENTER to confirm and open the "sanification" screen;
- UP or DOWN to enable manual sanitisation;
- ESC repeatedly to return to the "Main" screen, or alternatively ESC twice to return to the management menu to set the sanitisation cycle times and mode.

#### Automatic sanitisation mode

Available only when the time bands are enabled.

Used to activate the sanitisation cycles at the "end of the day", that is, at the end of the last steam production time band.

From the "sanification" submenu press:

- ENTER to confirm and open the "sanification" screen;
- UP or DOWN to enable automatic sanitisation;
- ESC repeatedly to return to the "Main" screen, or alternatively ESC twice to return to the management menu to set the sanitisation cycle times and mode.

#### Setting the sanitisation times and phases

From the "sanification" submenu press:

- ENTER to enter the "sanification" screen;
- ENTER values for T1 and T2;
- UP or DOWN to set the duration of the cycles in minutes;
- ENTER until moving the cursor to the start of the screen;
- DOWN to access the "San. phase 1" (T1) screen;
- ENTER to enable the desired functions (with the UP or DOWN button) and press ENTER to move the cursor to the next parameter;
- ENTER until moving the cursor to the start of the screen;
- DOWN to access the "San. phase" (T2) screen, and set the second sanitisation cycle;
- ESC repeatedly to return to the "Main" screen.

## 7.8 Advanced settings (qualified personnel only)



**Important:** these settings should only be made by qualified personnel, improper uses may cause serious damage.

### Automatic water drain

#### Drain due to set point reduction

The humidifier empties a small quantity of water if the requested production is decreased by more than 33%. With less water the humidifier can reach the new steam production set point more quickly.

To disable this function, from the "Maint SW" menu press:

- ENTER to access the "Additional features" screen;
- ENTER to move the cursor to the "Drain by low setp" parameter;
- UP or DOWN to disable (NO) or enable (YES, default) the function;
- ENTER to confirm;
- ESC repeatedly to return to the "Main" screen.

Drain due to inactivity

If the humidifier not used for an extended period, the water in the cylinder should be drained to prevent stagnation and hygiene risks. To set this function, from the "Maint SW" submenu press:

- ENTER to access the "Additional features" screen;
- ENTER to move the cursor to the "Inactivity drain" parameter;
- UP or DOWN to enable (YES, default) disable (NO) the function;
- ENTER until moving the cursor to the start of the screen;
- DOWN to access the second "Additional features" screen;
- ENTER to move the cursor to the "Inactivity drain" parameter ;
- UP or DOWN to modify the number of days without steam production after which the automatic drain cycle is activated (default 3 days);
- ENTER to confirm ;
- ESC repeatedly to return to the "Main" screen.

Periodical drain (for water rich in residues)

Operation with water containing considerable traces of humus, lime, debris, may affect the efficiency and the operation of the humidifier. In these cases a periodical complete drain cycle of the water contained in the cylinders may be useful in helping to discharge the sediments. To automatically set the periodical drain cycle, from the "Maint SW" submenu press:

- ENTER to access the "Additional features" screen;
- ENTER to move the cursor to the "Periodic flushing" parameter;
- UP or DOWN to enable (YES) disable (NO, default) the function;
- ENTER to move the cursor to the last "Periodic flushing" parameter;
- UP or DOWN to set the number of hours between one drain cycle and the next (default 24 h);
- ESC repeatedly to return to the "Main" screen.

Drain without power

The evaporation of the water causes an accumulation of salts inside the cylinders, leading to an increase in conductivity. The humidifier thus automatically runs a short drain cycle (drain to dilute) to lower the conductivity.

During the drain cycle the contactor is open, so that the water drained does not conduct current (in this short period, in fact, steam production is momentarily stopped). To perform the drain cycle with the contactor closed, from the "Maint SW" submenu press: :

- ENTER to access the "Additional features" screen;
- ENTER to move the cursor to the "Unpowered drain" parameter;
- UP or DOWN to disable (NO) or enable (YES, default) the function;
- ESC repeatedly to return to the "Main" screen.

**Disabling the "Cylinder pre-exhaustion" and "Cylinder exhaustion" alarms**

To disable these two alarm signals, press:

- ENTER to access the "Additional features" screen;
- ENTER to move the cursor to the "Cylinder warning" parameter;
- UP or DOWN to disable (NO) or enable (YES, default) the function;
- ENTER to confirm;
- ESC repeatedly to return to the "Main" screen.

**"Delay stop steam" function**

Used to delay the interruption of steam production after a steam off request.

To set the delay time (maximum 120 seconds), from the "Maint SW" submenu press:

- ENTER to enter the second "Additional features" screen;
- ENTER to move the cursor to the "force cond." parameter;
- UP or DOWN to set the conductivity value (up to 2000  $\mu\text{S}/\text{cm}$ );
- ENTER to confirm;
- ESC repeatedly to return to the "Main" screen.

**Conductivity of the supply water**Forced conductivity setting

To enable the forced conductivity setting, from the "Maint SW" submenu press:

- ENTER to enter the second "Additional features" screen;
- ENTER to move the cursor to the "force cond." parameter;

- UP or DOWN to set the conductivity value (up to 2000  $\mu\text{S}/\text{cm}$ );
- ENTER to confirm;
- ESC repeatedly to return to the "Main" screen.

High conductivity alarms

To determine the high conductivity alarm thresholds, from the "Maint SW" menu press:

- ENTER until reaching the "Thresholds conduct." screen;
- ENTER to move the cursor to the "Warning" parameter (1,000  $\mu\text{S}/\text{cm}$ );
- UP or DOWN to set the conductivity pre-alarm value (signal only);
- ENTER to confirm and set the conductivity alarm value (1250  $\mu\text{S}/\text{cm}$ ; signal and stop steam production);
- ENTER to confirm;
- ESC repeatedly to return to the "Main" screen.



**Note** The alarms are not activated if the forced conductivity setting is enabled.

Duration and frequency of the drain to dilute cycle

Based on the type of water used, the duration and the frequency of the automatic drain cycle can be set as a percentage of the rated value.

From the "Maint SW" submenu press:

- ENTER until reaching the "Thresholds conduct." screen;
- ENTER to move the cursor to the "Drain duration" parameter (default 100%);
- UP or DOWN to set the percentage of the duration;
- ENTER to confirm and set the percentage of the frequency between one drain cycle and the next (default: 100%);
- ENTER to confirm;
- ESC repeatedly to return to the "Main" screen.

**7.9 Copying the settings (backup)**

This function is used to save a copy of the settings (e.g.: names of the essences, fan operation, time band settings,...). The copy saved can be restored when needed, for example when errors are made in the settings.

A copy of the settings should be made for each required configuration.

Creating a copy of the settings

From the "Maint SW" submenu press:

- ENTER to confirm;
- DOWN until displaying the "Backup" screen;
- ENTER to move the cursor to YES/NO;
- UP or DOWN to set YES;
- ENTER to confirm;
- ESC repeatedly to return to the "Main" screen.

Restoring the last copy

From the "Maint SW" submenu press:

- ENTER to confirm;
- DOWN until displaying the "Restore" screen;
- ENTER to move the cursor to the YES/NO;
- UP or DOWN to set YES;
- ENTER to confirm.
- ESC repeatedly to return to the "Main" screen.



**Important:** All the changes made since the last copy was saved will be lost.

## 7.10 GSM (send SMS on alarms)

By setting the GSM function, when alarms are activated the humidifier sends an SMS (short message service) to the mobile phone number configured.

**Important:** to send an SMS, the humidifier must be fitted with the electronic board PCO100MDM0, the GSM modem kit PLW0PGSM00 and a SIM card inserted in the modem (for installation see par. "5.2" page 17).

Example of an SMS:  
 "CAREL SPA STEAM BATH New active alarm Cylinder full 16:15 28/ 6/ 7(\*)  
 CAREL – humiSteam code application ..... and version ....."

<sup>(\*)</sup>Time/date (and format) correspond to the humidifier data  
**Important:** the humidifier only has one data line (baud rate and protocol). Enabling the SMS function disables the supervisory network (and vice-versa).

### Enabling the SMS function

- From the "network" submenu:
- ENTER to display the "Supervisor" screen;
  - ENTER to move the cursor to the "Ident. number for BMS net" parameter;
  - UP or DOWN to set the identifier number (\*) (default: 1);
  - ENTER to confirm and move the cursor to the "Baud rate" parameter;
  - UP or DOWN to set the baud rate (for SMS 9600BPS);
  - ENTER to confirm and move the cursor to the "Protocol" parameter;
  - UP or DOWN to select the GSM protocol;
  - ENTER to confirm;
  - ESC repeatedly to return to the "Main" screen.

### SMS settings

- From the "GSM" submenu
- ENTER to display the "SMS" screen;
  - ENTER to move the cursor to the "Text on SMS mask" parameter;
  - UP or DOWN to set the text (see "Characters and symbols for naming the essences" page 21);
  - ENTER to set the mobile phone number (\*\*);
  - DOWN to move the cursor to the following "SMS" screen, to display the strength of the GSM signal and the status of the modem;
  - ESC repeatedly to return to the "Main" screen.

<sup>(\*)</sup> This parameter can be used to associate an identifier to each humidifier. This function is required to identify each unit within a supervisory network.

**Important:**

- only use numeric characters;
- disable the PIN code on the SIM card;
- the messages can only be sent in SMS format;
- the SMS messages are subject to the fees and conditions of the operator providing the SIM card.

CAREL declines all responsibility for the failure to send and receive SMS messages.

## 7.11 Enable supervisor network

- From the "network" submenu:
- ENTER to display the "Supervisor" screen;
  - ENTER to move the cursor to the "Ident. number for BMS net" parameter;
  - UP or DOWN to set the identifier for each unit <sup>(\*)</sup>;
  - ENTER to confirm and move the cursor to the "Baud rate" parameter;
  - UP or DOWN to set the baud rate for the network in question;
  - ENTER to confirm and move the cursor to the "Protocol" parameter;
  - UP or DOWN to select the type of protocol;
  - ENTER to confirm;
  - ESC repeatedly to return to the "Main" screen.

<sup>(\*)</sup> For example, to connect three humidifiers to a supervisory network, an identifier must be assigned to each unit. The supervisor PC will recognise the three humidifiers using this number.

### ON/OFF from supervisor

To enable the humidifier to be switched ON/OFF from the supervisor, from the "User" submenu press:

- ENTER to confirm;
- DOWN until displaying the screen with the "enable supervisory ON/OFF" parameter;
- ENTER to move the cursor to the value of the parameter (YES/NO);
- UP or DOWN to enable ON/OFF from the supervisor (YES);
- ESC repeatedly to return to the "Main" screen.

## 7.12 Manual procedures (qualified personnel only)

**Important:** these procedures should only be carried out by qualified personnel, improper use may cause serious damage.

These procedures are used to manually test the main functions and the operation of the humidifier.

To enable the manual procedures, the humidifier must not be producing steam (steam OFF from "ON/OFF quick access" screen).

### Accessing the manual procedures:

- From the "Maint HW" screen press:
- ENTER to confirm;
  - DOWN to select the "Man. procedure" screen;
  - ENTER to confirm and move the cursor to field the enable the procedure (YES/NO);
  - UP or DOWN to enable (YES);
  - ENTER to confirm and move the cursor to "contactor";
  - UP or DOWN to test the contactor (ON) and at the end of the test, UP or DOWN to disable (OFF). Repeat the same procedure for the other functions that to be tested (on the three consecutive screens);
  - at the end of the test return to the first "Man. procedure" screen and disable the procedure (from YES to NO). The humidifier will return to normal operation;
  - ESC repeatedly to return to the "Main" screen.

Manual procedure functions (distributed over three consecutive screens):

Contactor	Screen 1
Fill	
Drain	
Alarm	
Light	
Reset hour count	
Supply fan	Screen 2
Exhaust fan	
Essence 1,2,3	
Health	
Emptying cylinder <sup>(*)</sup>	Screen 3
Pre-cleaning cylinder <sup>(**)</sup>	

<sup>(\*\*)</sup> Humidifier automatically reset at the end of the test.

## 7.13 Displaying the alarms

From the alarm log submenu, press ENTER to display the alarms (type of alarm, date and time)

The humidifier saves up to 200 alarms.

alarm	meaning and cause	solution	reset	alarm relay	consequence
Alarm: EP Low Production (cylinder OFF)	excessive reduction in steam production, or excessive foam in the cylinder.	Perform maintenance on the cylinder	manual	active	stop steam production
Alarm: EF Lack of water (cylinder OFF)	no water in the cylinder	<ol style="list-style-type: none"> <li>1. check that the supply hose and the internal hoses are not blocked or choked and that there is sufficient pressure (0.1 to 0.8 MPa, 1 to 8 bars);</li> <li>2. check the operation of the fill solenoid valve;</li> <li>3. check that the steam outlet is not operating with excessive backpressure, preventing the flow of water into the cylinder by gravity;</li> <li>4. check that the steam outlet hose is not choked and that there are no pockets of condensate</li> </ol>	automatic (automatic water return procedure)	active	stop steam production
Alarm: Ed Drain alarm (Cylinder OFF)	drain malfunction	check the water drain circuits and the correct operation of the electric drain pump	manual	active	stop steam production
Alarm: EL Low urrent (Cylinder OFF)	power not available; when the unit is activated no steam is produced	with the unit off and disconnected from the mains, check the electrical connections.	manual	active	stop steam production
Alarm: EH High current (Cylinder OFF)	probable fault in the electrodes or water temporarily too conductive(especially when restarting after a short stop)	<ol style="list-style-type: none"> <li>1. check the operation of the electric drain pump;</li> <li>2. check the seal of the fill solenoid valve when not energised; drain some of the water and re-start.</li> </ol>	manual	active	stop steam production
Alarm: EC High conductivity (Cylinder OFF)	high supply water conductivity	<ol style="list-style-type: none"> <li>1. check the limit threshold set;</li> <li>2. switch the unit off and clean the electrodes that measure of the conductivity of the water; if the problem persists, change the origin of the supply water or use a suitable treatment system (partial demineralisation).</li> </ol> <p><b>Note:</b> the problem is not resolved by softening the supply water</p>	manual	active	stop steam production
Warning: Ec High conductivity	pre-alarm: high supply water conductivity	<ol style="list-style-type: none"> <li>1. check the conductivity of the supply water, if necessary use a suitable treatment system (partial demineralisation).</li> </ol> <p><b>Note:</b> the problem is not resolved by softening the supply water</p>	automatic	not active	signal only
Alarm: E= High temp.	pre-alarm: high temperature	check the operation of the probe and the high temperature parameter	automatic	not active	signal only
Alarm: E_ Low temp.	pre-alarm: low temperature	check the operation of the probe and the low temperature parameter	automatic	not active	signal only
Alarm: E3 Probe 1 fault or offline	1st probe disconnected or faulty alarm	check the connection of the probe, and the type of probe selected on the: "type of probe" screen ("Maint HW" submenu)	automatic	active	stop steam production
Alarm: E4 Probe 2 fault or offline	2nd probe disconnected or faulty alarm	check the connection of the probe, and the type of probe selected on the: "type of probe" screen ("Maint HW" submenu)	automatic	not active	stop steam production
Warning: EA Foam cylinder	excessive foam in the cylinder during boiling	<p>the entrainment of foam is generally due to the presence of surfactants in the water (lubricants, solvents, detergents, water treatment agents, softeners) or an excessive concentration of dissolved salts:</p> <ol style="list-style-type: none"> <li>1. drain the water supply lines;</li> <li>2. clean the cylinder make sure a softener is not used (if so, use another source of water or reduce the softening).</li> </ol>	manual	not active	signal only
Warning: CP Pre-exhaustion cylinder	pre-alarm: cylinder being depleted	perform maintenance and/or replace the cylinder	manual	not active	signal only
Alarm: EU full cylinder (cylinder OFF)	cylinder full with unit off	<p>with the unit off:</p> <ol style="list-style-type: none"> <li>1. check for any leaks from the fill solenoid valve or the condensate return from the hose, check that the level sensors are clean</li> </ol>	manual	active	stop steam production
Warning: CL Exhaustion cylinder	cylinder depleted	perform maintenance and/or replace the cylinder	manual	active	stop steam production

alarm	meaning and cause	solution	reset	alarm relay	consequence
Warning: CY Cylinder maintenance recommended	cylinder maintenance recommended	perform maintenance and/or replace the cylinder	manual (reset)	not active	signal only
Alarm: Mn Cylinder maintenance mandatory (cylinder OFF)	cylinder maintenance required	Replace the cylinder	manual (reset counter)	active	stop steam production
Clock board fault	Clock error backup battery completely discharged or general problems with the clock	Electronic microprocessor controller installed inside the humidifier electrical compartment	manual	not active	signal only
Alarm: utility board 1 or 2	utilities board offline or faulty	- connect the board - deactivate the utility functions relating to the alarm signal	automatic	active	signal only

Tab. 7.a

Cylinder OFF= the cylinder is not able to produce steam

The alarm button performs a number of actions, depending on how many times it is pressed.

Action/Pressing the button	Effect
first time	display the alarm code; if more than one alarm is active at the same time, the codes are displayed in sequence by pressing UP or DOWN.
second time	if the cause of the alarm has been resolved, the alarm is no longer displayed and the corresponding relay is deactivated (if fitted)
third time	the cause of the alarm has been resolved, the alarm is no longer displayed, the corresponding relay is deactivated and the display shows: 
fourth time	return to the main screen

Tab. 7.b

### 7.14 Info-menu

Series of screens that describe the functions and the use of the screens in the management menu.

Enabling "info-menu" (disabled by default), all access to the submenus will be preceded by a descriptive screen (to continue navigating, press ENTER).

#### Enabling info-menu

From the "utility" submenu press:

- ENTER to confirm;
- DOWN until displaying the screen with the "enable info?" parameter;
- ENTER to move the cursor to the value of the parameter (YES/NO);
- UP or DOWN to enable the info-menu function (YES);
- ESC repeatedly to return to the "Main" screen;

### 7.15 Mechanically draining the water in the cylinder

Drain due to gravity without activating the humidifier, recommended if:

- the humidifier is decommissioned, to empty the cylinder without switching on the humidifier;
- to eliminate the residual water following a drain cycle by pump.

#### Mechanical drain:

- make sure that the humidifier is not powered;
- remove the cover (see par. "1.6" page 8);
- activate the mechanical device under the cylinder (see part. A Fig. 7.a).

Models UE001 to UE018

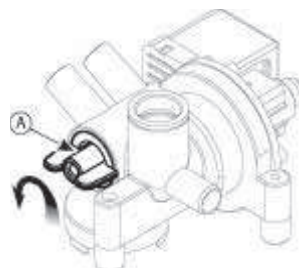

Models UE025 to UE065



Fig. 7.a

#### Other types of drains:

- manual (from "ON/OFF quick access" screen, see page 19; and manual procedure, see par. "7.12" page 25);
- automatic (see par. "Automatic water drain" page 23).

## 8. MAINTENANCE AND SPARE PARTS

### 8.1 Spare parts for models UE001 to UE018

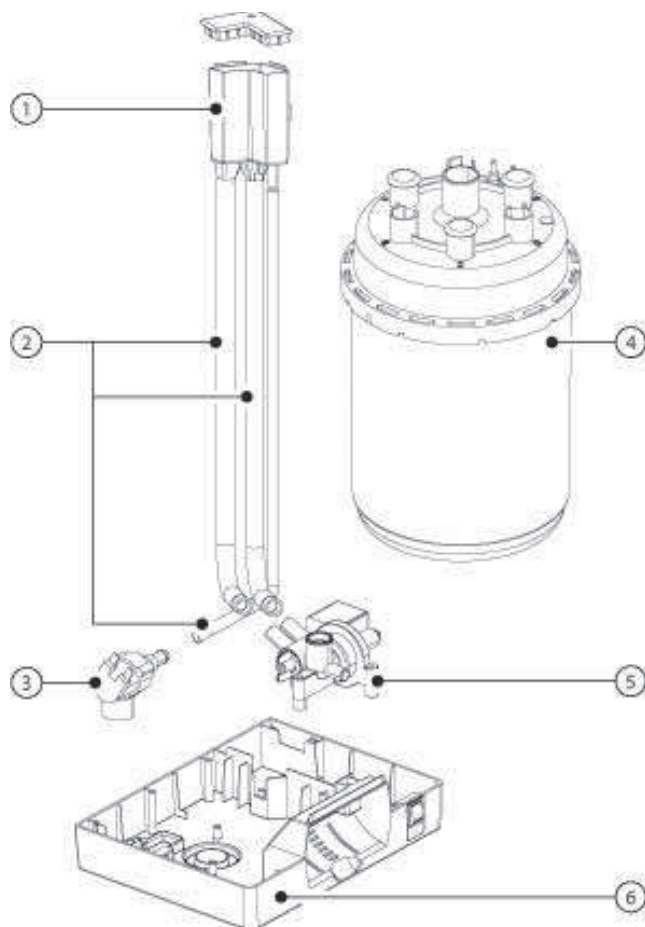

Fig. 8.a

Key to Figs. 8a and 8.b:

- 1 tank
- 2 internal pipe kit
- 3 fill solenoid valve kit
- 4 cylinder
- 5 manifold with drain pump
- 6 plastic base
- 7 plastic humidifier top
- 8 TAM (transformer for measuring the current)
- 9 transformer
- 10 contactor
- 11 fuse carrier
- 12 pCO<sub>e</sub> expansion board (controller I/O expansion)
- 13 microprocessor electronic controller
- 14 power terminals
- 15 utility terminal block
- 16 plastic base
- 17 switch
- 18 terminal with liquid crystal display

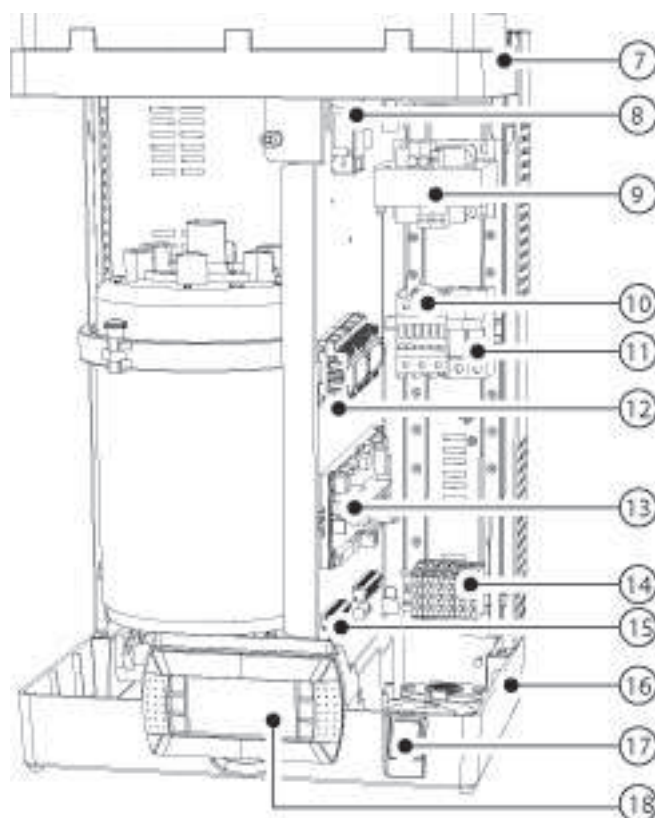

Fig. 8.b

Table of water circuit, electrical and electronic spare parts, UE001 to 018

	spare part code								position	figure
	UE001	UE003	UE005	UE008	UE009	UE010	UE015	UE018		
<b>Water circuit</b>										
Fill tank + conductivity meter	UEKVASC000								1	8.a
Fill solenoid valve kit	KITVC10006				KITVC10011				3	8.a
Internal pipe kit	UEKT10000S				UEKT10000M				2	8.a e 8.c
Plastic humidifier base	18C565A019								16	8.b
Plastic humidifier top	18C476A011								7	8.b
Assembled f/d manifold + pump	18C565A018								3	8.a
<b>Electrical and electronics</b>										
Display terminal	HCT1EWF000								11	8.b
TAM (current transformer)	09C565A042								8	8.b e 8.d
Contactur	0203012AXX	0203013AXX								
Power transformer: 230-400/24-24 V	09C565A016								9	8.b e 8.d
Microprocessor electronic controller	HCA0EW0000								13	8.b e 8.d
pCO <sub>e</sub> expansion board (Controller I/O expansion)	PCOE00TLN0								12	8.b
Fuse carrier	0606192AXX								11	8.b e 8.d
F1 - F2 230 to 400 Vac power fuses	0605321ALG								-	see wiring diagrams
F4 Transformer secondary fuse (F41)	0605581AXX (F41) 0605620AXX (F42)								-	see wiring diagrams
F5 - F6 pCO <sub>e</sub> fuse	0605615AXX								-	
AP1 - AP2 Terminal fuse	0605595AXX								-	see wiring diagrams
Connection cable between terminal and electronic controller	S90CONN002								-	
PF1 Controller fuse	0605604AXX								-	see wiring diagrams

Tab. 8.a

Table of spare part codes, single-phase cylinders UE001 to 005, electrode and gasket kit

Model		UE001	UE003	UE005	UE009
STANDARD disposable cylinders	200/230 Vac 3~, conductivity 350 to 1250 µS/cm	BLOS1F00H1	BLOS1F00H1	BLOS2F00H0	BLOS3F00H0
SPECIAL disposable cylinders	200/230 Vac 3~, conductivity 125 to 350 µS/cm	BLOS1E00H1	BLOS1E00H1	BLOS2E00H0	BLOS3E00H0
SPECIAL openable cylinders	200/230 Vac 3~, conductivity 125 to 350 µS/cm	BLCS1E00W1	BLCS1E00W1	BLCS2E00W0	BLCS3E00W0
Electrode and gasket kit	200/230 Vac 3~, conductivity 350 to 1250 µS/cm	KITBLC1E0	KITBLC2E0	KITBLC2E0	KITBLC3E0
	200/230 Vac 3~, conductivity 125 to 350 µS/cm	KITBLC1F0	KITBLC2F0	KITBLC2F0	KITBLC3F0
Electrode gasket kit		KITBLC1FG0	KITBLC2FG0	KITBLC2FG0	KITBLC3FG0

Tab. 8.b

Table of spare part codes, three-phase cylinders UE003 to 018, electrode and gasket kit

Model		UE003	UE005	UE008	UE010	UE015	UE018
STANDARD disposable cylinders	200/230 VAC 3~, conductivity 350 to 1250 µS/cm	BLOT1B00H1	BLOT2B00H0	BLOT2B00H0	BLOT3B00H0	BLOT3A00H0	BLOT3B00H0
	400 VAC 3~, conductivity 350 to 750 µS/cm	BLOT1C00H1	BLOT2C00H0	BLOT2C00H0	BLOT3C00H0	BLOT3B00H0	BLOT3B00H0
SPECIAL disposable cylinders	200/230 VAC 3~, conductivity 125..350 µS/cm	BLOT1A00H1	BLOT2A00H1	BLOT2A00H1	BLOT3A00H1	BLOT3A00H1	BLOT3A00H1
	400 VAC 3~, conductivity 125 to 350 µS/cm	BLOT1A00H1	BLOT2B00H0	BLOT2B00H0	BLOT3B00H0	BLOT3B00H0	BLOT3B00H0
	400 VAC 3~, conductivity 750 to 1250 µS/cm	BLOT1D00H1	BLOT2D00H0	BLOT2D00H0	BLOT3D00H0	BLOT3D00H0	BLOT3D00H0
SPECIAL openable cylinders	200/230 VAC 3~, conductivity 125..350 µS/cm	BLCT1A00W1	BLCT2A00W1	BLCT2A00W1	BLCT3A00W1	BLCT3A00W1	BLCT3A00W1
	400 VAC 3~, conductivity 125 to 350 µS/cm	BLCT1A00W1	BLCT2B00W0	BLCT2B00W0	BLCT3B00W0	BLCT3B00W0	BLCT3B00W0
	400 VAC 3~, conductivity 350 to 750 µS/cm	BLCT1C00W1	BLCT2C00W0	BLCT2C00W0	BLCT3C00W0	BLCT3B00W0	BLCT3B00W0
	400 VAC 3~, conductivity 750 to 1250 µS/cm	BLCT1D00W1	BLCT2D00W0	BLCT2D00W0	BLCT3D00W0	BLCT3D00W0	BLCT3D00W0
Electrode and gasket kit	Electrode kit 200/230 Vac 3~, 125/350 µS/cm	KITBLCT1A0	KITBLCT2A0	KITBLCT2A0	KITBLCT3A0	KITBLCT3A0	KITBLCT3A0
	Electrode kit 200/230 Vac 3~, 350/1250 µS/cm	KITBLCT1B0	KITBLCT2B0	KITBLCT2B0	KITBLCT3B0	KITBLCT3B0	KITBLCT3B0
	Electrode kit 400 Vac 3~, 125/350 µS/cm	KITBLCT1A0	KITBLCT2B0	KITBLCT2B0	KITBLCT3B0	KITBLCT3B0	KITBLCT3B0
	Electrode kit 400 Vac 3~, 350/750 µS/cm	KITBLCT1C0	KITBLCT2C0	KITBLCT2C0	KITBLCT3C0	KITBLCT3C0	KITBLCT3C0
	Electrode kit 400 Vac 3~, 750/1250 µS/cm	KITBLCT1D0	KITBLCT2D0	KITBLCT2D0	KITBLCT3D0	KITBLCT3D0	KITBLCT3D0
Electrode gasket kit		KITBLC1FG0	KITBLC2FG0	KITBLC2FG0	KITBLC3FG0	KITBLC3FG0	KITBLC3FG0

Tab. 8.c

8.2 Spare parts, models UE025 to UE065

installer  
user  
service

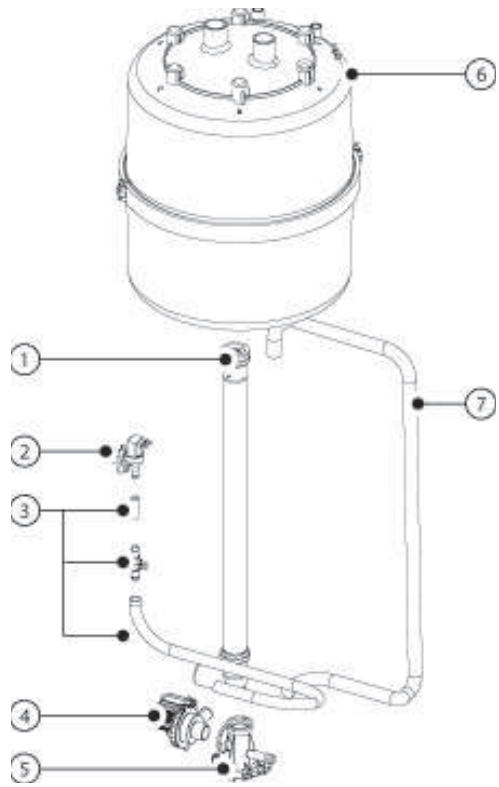

Fig. 8.c

Key:

- 1 drain circuit
- 2 fill solenoid valve kit
- 3 internal pipe kit
- 4 drain pump kit
- 5 manifold
- 6 cylinder
- 7 drain pump hose
- 8 TAM (transformer for measuring the current)
- 9 contactor
- 10 transformer
- 11 pCOe expansion board (controller I/O expansion)
- 12 pump control relay
- 13 fuse carrier
- 14 microprocessor electronic controller
- 15 power terminals
- 16 utility terminal block
- 17 cable clamp
- 18 switch
- 19 terminal with liquid crystal display (fitted on the cover of the electrical compartment)

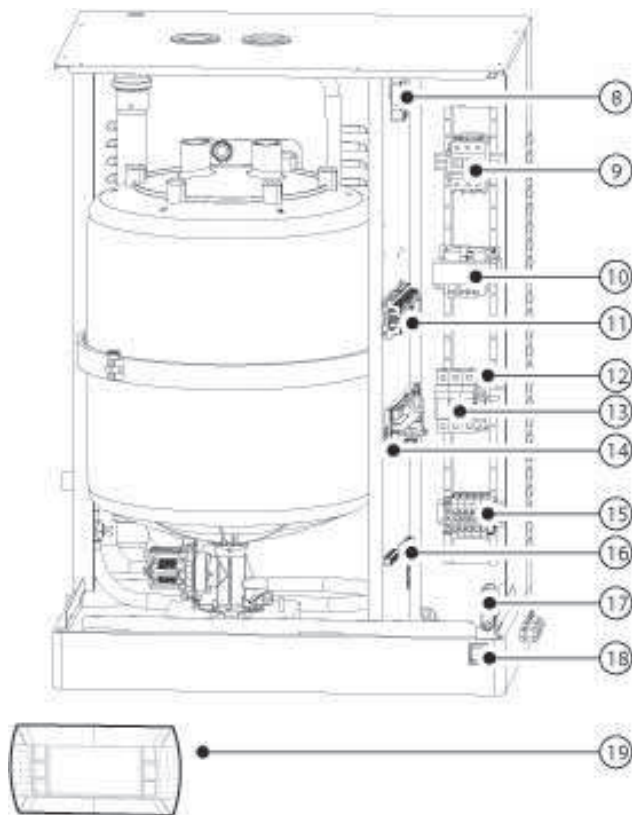

Fig. 8.d

Table of water circuit, electrical and electronic spare parts, UE025 to UE065

description	spare part code				position	figure	
	UE025	UE035	UE045				UE065
			400 V	230 V			
<b>Water circuit</b>							
Drain pump hose			13C479A001		7	8.c	
Manifold			18C499A001		5	8.c	
Drain pump kit			KITPS00000		4	8.c	
Internal pipe kit		UEKT10000L		UEKT1000XL	3	8.a e 8.c	
Double check valve kit			FWHDCV0000		-		
Conductivity meter kit			KITCN00000		-		
Fill solenoid valve kit		KITVC10058	KITVC10070	KITVC10070	2	8.c	
Drain circuit		13C565A031			1	8.c	
<b>Electrical and electronics</b>							
Display terminal			HCT1EWF000		19	8.b	
pCOe expansion board (controller I/O expansion)			PCOE00TLN0		11	8.d	
TAM (current transformer)			09C565A042		8	8.b e 8.d	
Contactora (V= 400)	0203013AXX		0203014AXX	0203007AXX			
Power transformer: 230/400-24V			09C565A044		10	8.b e 8.d	
Microprocessor electronic controller			HCA0EW0000		14	8.b e 8.d	
Fuse carrier			0606193AXX		13	8.b e 8.d	
Pump control relay			0102001AXX		12	8.d	
F1 - F2 230 to 400Vac power fuses			0605319AXX		-	see wiring diagrams	
F3 Pump fuse			0605319AXX		-	see wiring diagrams	
F4 Transformer secondary fuse			0605624AXX		-	see wiring diagrams	
F5 - F6 pCOe fuse			0605615AXX		-	see wiring diagrams	
AP1 - AP2 Terminal fuse			0605595AXX		-	see wiring diagrams	
Connection cable between terminal and HHPC			S90CONN002		-		
PF1 Controller fuse			0605604XXX		-	see wiring diagrams	

Tab. 8.d

Table of spare parts for standard and special cylinders UE025 to UE065

Description		UE025	UE035	UE045	UE065
STANDARD disposable cylinders	200/230V 3ph cylinder, conductivity 350 to 1250 µS/cm	BL0T4C00H0	BL0T4B00H0	BL0T5A00H1	-
	400V 3ph Cylinder, conductivity 350 to 1250 µS/cm	BL0T4C00H0	BL0T4D00H0	BL0T4C00H0	BL0T5C00H0
SPECIAL disposable cylinders	200/230V 3ph Cylinder, conductivity 125 to 350 µS/cm	BL0T4B00H0	BL0T4B00H0	BL0T5A00H1	--
	400V 3ph Cylinder, conductivity 125 to 350 µS/cm	BL0T4C00H0	BL0T4C00H0	BL0T4B00H0	BL0T5B00H0
SPECIAL openable cylinders	200/230V 3ph Cylinder, conductivity 125 to 350 µS/cm	BLCT4B00W0	BLCT4B00W0	BLCT5A00W0	--
	200/230V 3ph Cylinder, conductivity 350 to 1250 µS/cm	BLCT4C00W0	BLCT4B00W0	BLCT5A00W0	--
	400V 3ph Cylinder, conductivity 125 to 350 µS/cm	BLCT4C00W0	BLCT4C00W0	BLCT4B00W0	BLCT5B00W0
	400V 3ph Cylinder, conductivity 350 to 1250 µS/cm	BLCT4C00W0	BLCT4D00W0	BLCT4C00W0	BLCT5C00W0
Electrode and gasket kit	200/230V 3ph Cylinder, conductivity 125 to 350 µS/cm	KITBLCT4B0	KITBLCT4B0	KITBLCT5A0	--
	200/230V 3ph Cylinder, conductivity 350 to 1250 µS/cm	KITBLCT4C0	KITBLCT4C0	KITBLCT5A0	--
	400V 3ph Cylinder, conductivity 125 to 350 µS/cm	KITBLCT4C0	KITBLCT4C0	KITBLCT4B0	KITBLCT5B0
	400V 3ph Cylinder, conductivity 350 to 1250 µS/cm	KITBLCT4D0	KITBLCT4D0	KITBLCT4C0	KITBLCT5C0
Gasket kit		KITBLC4FG0	KITBLC4FG0	KITBLC4FG0	KITBLC5FG0

Tab. 8.e

### 8.3 Cleaning and maintenance of the cylinder

#### Replacement

**Important:** the cylinder must be only be replaced by qualified personnel, and with the humidifier unplugged from the power supply.

In normal conditions, the **disposable cylinders should be replaced after one year** (or 2500 hours of operation, if cleaned periodically), while the **openable cylinders last 5 years** (or 10,000 hours of operation, if cleaned periodically). They must be replaced immediately – even before the specified intervals – if any anomalies occur. For example, when the lime scale inside the cylinder prevents the correct flow of electric current.

#### Replacement procedure:

- empty all the water (see par. "7.15" page 27);
- turn off the humidifier (switch "0"), and open the mains disconnect switch on the power supply (safety procedure);
- wait for the humidifier and the cylinder to cool down;
- remove the front cover (see par. "1.6" page 8);
- disconnect the electrical cables from the top of the cylinder;
- release the cylinder from its fastening device and lift it up to remove it;
- insert the new cylinder (make sure that the model and the power supply of the new cylinder correspond to the rated data);
- fasten the cylinder;
- reconnect the electrical cables to the top of the cylinder;
- replace the front cover;
- switch on the humidifier.

#### Periodical checks

- After one hour** of operation: check for any significant water leaks.
- Every 15 days** or no more than 300 operating hours: check operation, the absence of significant water leaks, the general conditions of the casing. Check that during operation there are no arcs or sparks between the electrodes.
- Every 3 months** or no more than 1000 operating hours:
  - disposable cylinders: check operation, the absence of significant water leaks and if necessary replace the cylinder;
  - openable cylinders: if there are significantly blackened areas, check the deposits on the electrodes and clean them, using the specific electrode and gasket kit (see Tab. 8.c).
- Every year** or no more than 2500 operating hours:
  - disposable cylinders: replace;
  - openable cylinders: if there are significantly blackened areas, check the deposits on the electrodes and clean them, using the specific electrode and gasket kit (see Tab. 8.c).
- After 5 years** or no more than 10,000 operating hours: replace the openable cylinder.

After extended operation, or when using water rich in salts, the solid deposits that naturally form on the electrodes may grow until attaching to the inside wall of the cylinder. If these deposits are conductive the heat generated may overheat the plastic until it melts, with the risk of very hot water being released.

**Important:** In the event of water leaks, disconnect the power supply from the humidifier as the water may conduct electricity.

### 8.4 Cylinder connection, three-phase models UE025 to UE065

production (kg/h)	conductivity (µS/cm)	power supply (V)	
		230	400
25	125/350 µS/cm	A	B
	350/1250 µS/cm	B	B
35	125/350 µS/cm	A	B
	350/1250 µS/cm	A	B
45	125/350 µS/cm	A	A
	350/1250 µS/cm	A	B
65	125/350 µS/cm	/	A
	350/1250 µS/cm	/	B
	350/1250 µS/cm	/	B

Tab. 8.f

The cable ends must be tightened with the top nut to 3 Newton · m.

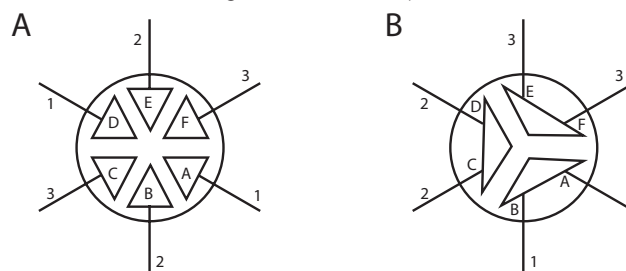

Fig. 8.e

### 8.5 Cleaning and maintenance of the other components

**Important:**

- when cleaning the plastic components do not use detergents or solvents;
- scale can be removed using a solution of 20% acetic acid and then rinsing with water.

#### Maintenance checks on other components:

- fill solenoid valve (Fig. 8.a part. 3 and Fig. 8.c part. 2). After having disconnected the cables and the tubing, remove the solenoid valve and make sure the inlet filter is clean; if necessary, clean with water and a soft brush;
- manifold with drain pump (Fig. 8.a part. 5). Check that there are no solid residues in the cylinder attachment, remove any impurities. Check that the gasket (o-ring) is not damaged or cracked, replace if necessary. Check that there are no solid residues in the drain hose;
- drain pump (Fig. 8.c part. 4). Disconnect the power supply, unscrew the fastening screws and remove any impurities (Fig. 8.a part. 6). Clean the tank from any deposits and check that the water flows freely from the tank to the drain (corresponding to the drain pump);
- tank (Fig. 8.a part. 1). Check that there are no obstructions or solid particles and that the conductivity measuring electrodes are clean, remove any impurities and rinse;
- internal pipe kit (Fig. 8.a part. 2 and Fig. 8.c part. 3). Check that the pipes and hoses are free and clear of impurities, remove any impurities and rinse.

**Important:** after having replaced or checked the water circuit, make sure that the connections are tight. Restart the unit and run a number of fill and drain cycles (from 2 to 4), after which, applying the safety procedure, check for any water leaks.

#### Fuses in the auxiliary circuits

Fuses	UE001 to 018	UE 025 to 065
F1 & F2	4 A fast-blow. 10.3x38	1 A fast-blow. 10.3x38
F3	-	1 A fast-blow. 10.3x38
F41 (s 1) F42 (s 2)	5 A T slow-blow 5x20 ceramic 2 Amp. T slow-blow 5x20 ceramic	2.5 A T slow-blow 5x20 ceramic -
F5 & F6	1 A T slow-blow 5x20 glass	1 A T slow-blow 5x20 glass
AP1 & AP2	6.3 A T slow-blow 5x20 ceramic	6.3 A T slow-blow 5x20 ceramic
controller fuse PF1	2 A T slow-blow 5x20 glass (minimum size of connection cables 1.5 mm <sup>2</sup> )	2 A T slow-blow 5x20 glass (minimum size of connection cables 1.5 mm <sup>2</sup> )

Tab. 8.f

## 9. WIRING DIAGRAMS

### 9.1 Diagram of single-phase models UE001 to UE009

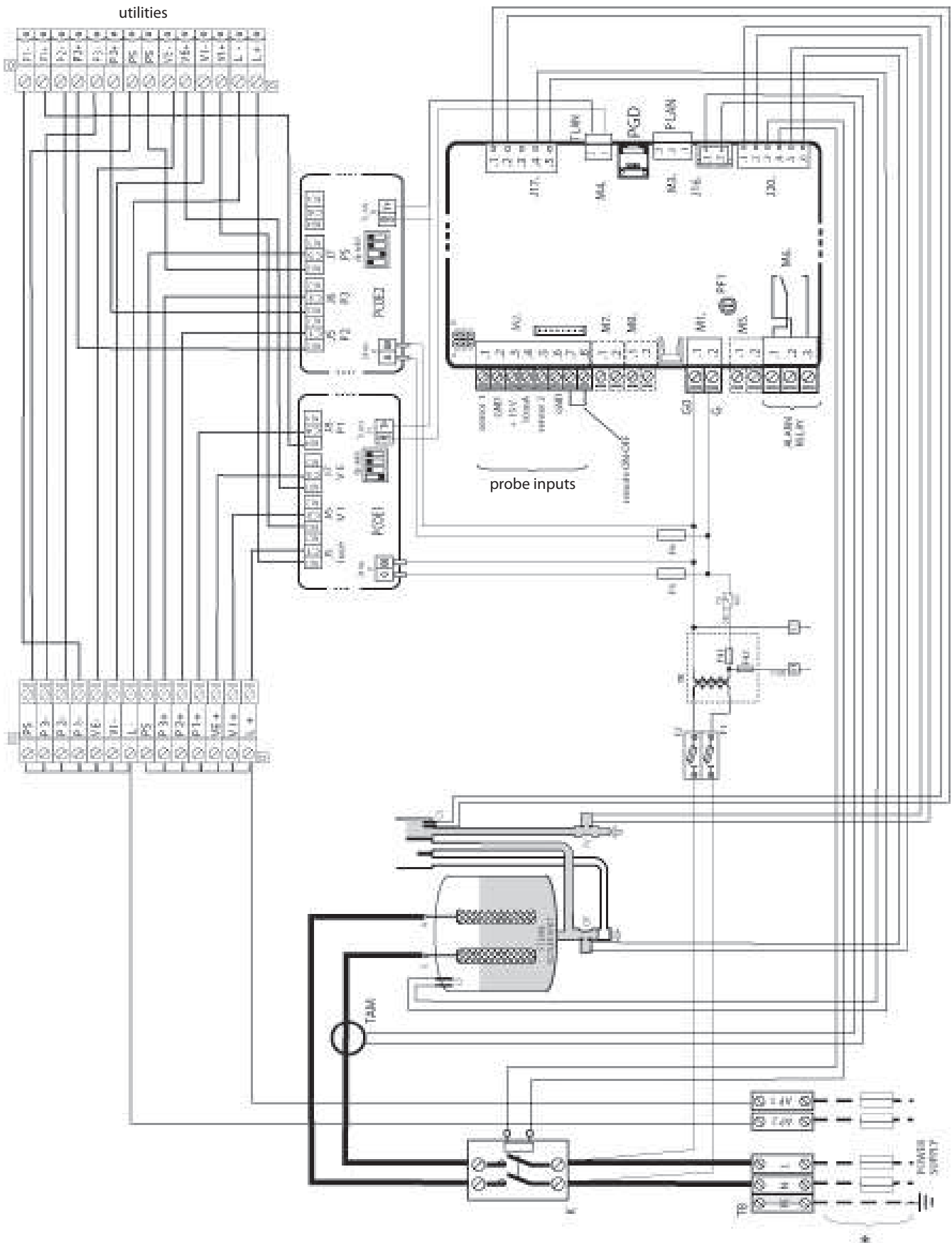

Fig. 9.a

9.2 Diagram of three-phase models UE003 to UE018

installer
user
service

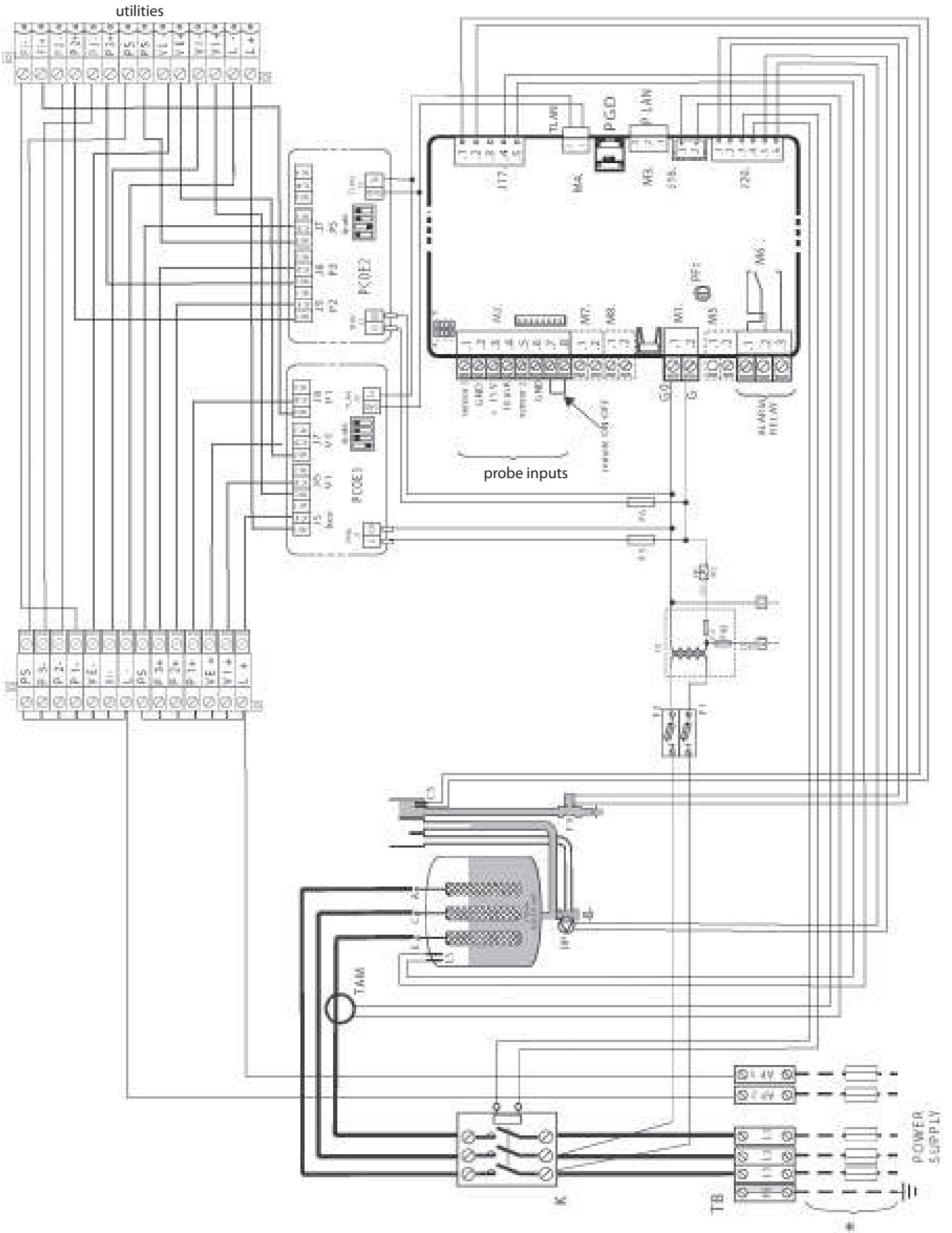
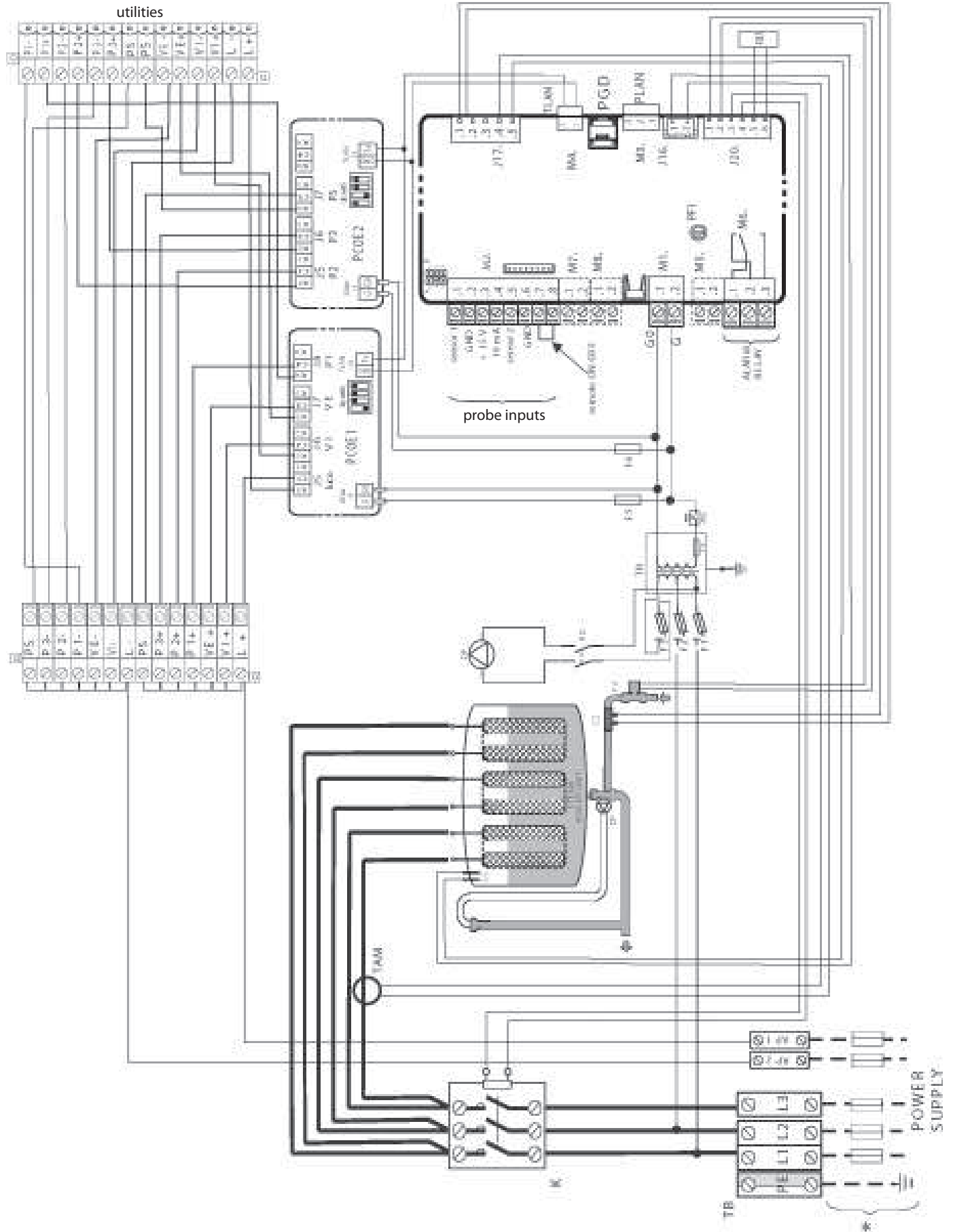

Fig. 9.b

9.3 Diagram of three-phase models UE025 to UE065



installer

user

service

Fig. 9.c

## 10. CARATTERISTICHE GENERALI E MODELLI

### 10.1 humiSteam Wellness models and electrical specifications

model	steam production <sup>(2)</sup> 4) (kg/h)	power <sup>(2)</sup> (kW)	power supply			rated specifications		cable <sup>(3)</sup> (mm <sup>2</sup> )	line fuses <sup>(3)</sup> (A / type)	wiring diagram (Fig.)
			code	voltage <sup>(1)</sup> (V - type)	current <sup>(2)</sup> (A)	TAM configuration <sup>(5)</sup>				
UE001	1.5	1.1	D	230 - 1~N	4.9	10.a	100	1.5	10 A / fast-blow	9.1
UE003	3.0	2.2	D	230 - 1~N	9.8	10.d	300	2.5	16 A / fast-blow	9.1
			K	230 - 3~	5.6	10.a	100	2.5	16 A / fast-blow	9.2
			L	400 - 3~	3.2	10.d	100	1.5	10 A / fast-blow	9.2
UE005	5.0	3.7	D	230 - 1~N	16.3	10.d	500	6.0	32 A / fast-blow	9.1
			K	230 - 3~	9.4	10.d	300	2.5	16 A / fast-blow	9.2
			L	400 - 3~	5.4	10.a	100	1.5	10 A / fast-blow	9.2
UE008	8.0	6.0	K	230 - 3~	15.1	10.d	500	6.0	32 A / fast-blow	9.2
			L	400 - 3~	8.7	10.a	100	2.5	16 A / fast-blow	9.2
UE009	9.0	6.7	D	230 - 1~	29.3	10.a	500	10.0	40 A / fast-blow	9.1
UE010	10.0	7.5	K	230 - 3~	18.8	10.a	300	6.0	32 A / fast-blow	9.2
			L	400 - 3~	10.8	10.d	300	2.5	16 A / fast-blow	9.2
UE015	15.0	11.2	K	230 - 3~	28.2	10.a	500	10.0	40 A / fast-blow	9.2
			L	400 - 3~	16.2	10.a	300	6.0	32 A / fast-blow	9.2
UE018	18	13.5	L	400 - 3~	19.5	10.a	300	6.0	32 A / fast-blow	9.2
UE025	25	18.7	K	230 - 3~	47.1	10.b	500	25	63 A / fast-blow	9.3
			L	400 - 3~	27.1	10.c	500	16	50 A / fast-blow	9.3
UE035	35	26.2	K	230 - 3~	65.9	10.b	500	35	100 A / fast-blow	9.3
			L	400 - 3~	37.9	10.b	300	16	60 A / fast-blow	9.3
UE045	45	33.7	K	230 - 3~	84.7	10.b	700	50	125 A / fast-blow	9.3
			L	400 - 3~	48.7	10.c	700	25	80 A / fast-blow	9.3
UE065	65	48.7	L	400 - 3~	70.4	10.c	700	35	100 A / fast-blow	9.3

Tab. 10.a

\* Version 0 with 1/2 phase in TAM

- (1) tolerance allowed on the rated mains voltage: -15%, +10%;  
 (2) tolerance on the rated values: +5%, -10% (EN 60335-1);  
 (3) recommended values refer to laying PVC or rubber cables in closed conduits, 20 m long;  
 (4) rated max instant steam production: the average steam production may be affected by external factors, such as: ambient temperature, water quality, steam distribution system;

(5) refer to the wiring diagrams to verify.



**Important:** the data are not absolute and if these differ from local standards, the latter must prevail;

#### Configurazioni e collegamenti TAM (trasformatore TAM configurations and connections (transformer for measuring the current))

**Important:** the configurations and connections are already made by CAREL, and no changes are required. The following diagrams represent possible connection modes and may be useful in the event of serious electrical malfunctions on the humidifier.

All operations must only be performed by qualified personnel, improper use may cause serious damage.

one cable turn

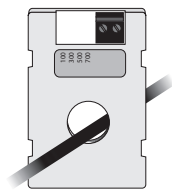

Fig. 10.a

one turn of the two cables of the same phase



Fig. 10.b

two cable turns of the same phase

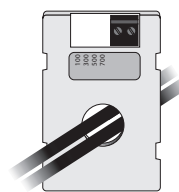

Fig. 10.c

one cable in "double turn" mode

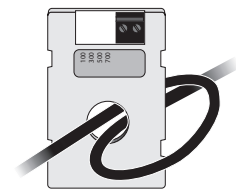

Fig. 10.d



**Important:** to avoid interference, separate the power cables from the probe cables.

## 10.2 Technical specifications

technical specifications	UEW model													
	UE001*	UE003*	UE003**	UE005*	UE005**	UE008**	UE009*	UE010**	UE015**	UE018**	UE025**	UE035**	UE045**	UE065**
<b>steam</b>														
connection (dia. mm)	230 V	22/30			30			1x40			2x40	--		
	400 V	22/30			30			1x40			2x40			
outlet pressure limits (Pa)	0/1500			0/1300			0/1350			0/2000				
<b>supply water</b>														
connection	3/4" G													
temperature limits (°C)	1 to 40													
pressure limits (MPa)	0.1 to 0.8 (1 to 8 bars)													
hardness limits (°fH)	≤ 40													
instant flow-rate (l/min)	0.6			1.1			5.85 (7 for UE045 A 230Vac)			7				
conductivity range (µS/cm)	125 to 1250													
<b>drain water</b>														
connection (dia. mm)	40													
typical temperature (°C)	≤ 100													
instant flow-rate (l/min)	7			22.5										
<b>environmental conditions</b>														
ambient operating temp. (°C)	1T40													
ambient operating humidity (% rH)	10 to 60													
storage temperature (°C)	-10T70													
storage humidity (% rH)	5 to 95													
index of protection	IP20													
<b>electronic controller</b>														
wellness	HCA0EW0000													
auxiliary voltage/frequency (V - Hz)	24 / 50/60													
maximum auxiliary power (VA)	180			40										
probe inputs (general features)	can be selected for the following signals: 0 to 1 Vdc. 0 to 10 Vdc. 2 to 10 Vdc. 0 to 20 mA. 4 to 20 mA. NTC input impedance: 60 kΩ with: 0 to 1 Vdc. 0 to 10 Vdc. 2 to 10 Vdc signals 50 Ω with: 0 to 20 mA. 4 to 20 mA signals													
active probe power supply (general features)	15 Vdc. 100 mA. protected against short-circuits +1 Vdc with 135 Ω load													
alarm relay outputs (general features)	250 V 5 A (2 A) - type of action-microswitching 1C													
remote enable input (general features)	voltage-free contact; max. resistance 50 Ω; Vmax= 24 Vdc; Imax= 6 mA													
<b>output</b>														
instant steam production <sup>(1)</sup> (kg/h)	1.5	3.0	3.0	5.0	5.0	8.0	9	10.0	15.0	18.0	25	35	45	65
power input at rated voltage (kW)	1.12	2.25	2.5	3.75	3.75	6.0	6.75	7.5	11.25	13.5	18.75	26.25	33.75	48.75

Tab. 10.b

\* single-phase, \*\* three-phase.

<sup>(1)</sup>= the average steam production is affected by factors such as: ambient temperature, water quality, steam distribution system

## 10.3 Models of steam hoses

code	UEW model													
	UE001W	UE003W	UE005W	UE008W	UE009W	UE010W	UE015W	UE018W	UE025W	UE035W	UE045W	UE065W		
steam outlet dia. (mm)	22	22	30	30	30	30	30	30	40	40	40	2x40		
max. capacity (kg/h)	1/1,5	3	5	8	9	10	15	18	25	35	45	65		
<b>CAREL steam hoses</b>														
code	inside dia. (mm)													
1312360AXX	22	√	√	-	-	-	-	-	-	-	-	-	-	-
1312365AXX	30	-	-	√	√	√	√	√	√	-	-	-	-	-
1312367AXX	40	-	-	-	-	-	-	-	-	√	√	√	√	√

Tab. 10.c

## 10.4 Models of concentrated jet steam distributors

			UEW model											
code			UE001W	UE003W	UE005W	UE008W	UE009W	UE010W	UE015W	UE018W	UE025W	UE035W	UE045W	UE065W
steam outlet dia. (mm)			22	22	30	30	30	30	30	30	40	40	40	2x40
max. capacity (kg/h)			1/1.5	3	5	8	9	10	15	18	25	35	45	65

CAREL SD steam distributors														
code	steam inlet dia. (mm)	max. capacity kg/h												
SDPOEM0012	22/30	3	1	1	-	-	-	-	-	-	-	-	-	-
SDPOEM0022	30	18	1	1	1	1	1	1	1	1	-	-	-	-
SDPOEM0000	30	18 (with 30 mm opening)	1	1	1	1	1	1	1	1	(2)*	(2)*	(4)**	(4)**

Tab. 10.d

1 = the humidifier is connected to just one distributor

(2) = the humidifier is connected to two distributors (using the "Y" kit: UEKY000000)

2 = the humidifier is fitted with two outlets and can be connected to two distributors

(4) = the humidifier is fitted with two outlets and can be connected to up to four distributors (using two "Y" kits)

\* = use CAREL "Y" kit code UEKY000000 (40 mm inlet and 2 x 30 mm outlets)

\*\* = use CAREL "Y" kit code UEKY000000 (40 mm inlet and 2 x 30 mm outlets)

## 10.5 Models of linear distributors

				UEW model											
code				UE001W	UE003W	UE005W	UE008W	UE009W	UE010W	UE015W	UE018W	UE025W	UE035W	UE045W	UE065W
steam outlet dia. (mm)				22	22	30	30	30	30	30	30	40	40	40	2x40
max. capacity kg/h				1/1.5	3	5	8	9	10	15	18	25	35	45	65

CAREL DP linear distributors														
code	steam inlet dia. (mm)	max. capacity kg/h	length in mm											
DP035D22R0	22	4	332	1	1	-	-	-	-	-	-	-	-	-
DP045D22R0	22	6	438	1	1	-	-	-	-	-	-	-	-	-
DP060D22R0	22	9	597	1	1	-	-	-	-	-	-	-	-	-
DP085D22R0	22	9	835	1	1	-	-	-	-	-	-	-	-	-
DP035D30R0	30	5	343	-	-	1	-	-	-	-	-	-	-	-
DP045D30R0	30	8	427	-	-	1	1	-	-	-	-	-	-	-
DP060D30R0	30	12	596	-	-	1	1	1	1	-	-	-	-	-
DP085D30R0	30	18	850	-	-	1	1	1	1	1	(2)*	-	-	-
DP105D30R0	30	18	1048	-	-	1	1	1	1	1	(2)*	-	-	-
DP125D30R0	30	18	1245	-	-	1	1	1	1	1	(2)*	-	-	-
DP085D40R0	40	25	834	-	-	-	-	-	-	-	1	(2)**	(2)**	(4)**
DP105D40R0	40	35	1015	-	-	-	-	-	-	-	1	1	(2)**	2
DP125D40R0	40	45	1222	-	-	-	-	-	-	-	1	1	1	2
DP165D40R0	40	45	1636	-	-	-	-	-	-	-	-	1	1	2
DP205D40R0	40	45	2025	-	-	-	-	-	-	-	-	1	1	-

Tab. 10.e

1 = the humidifier is connected to just one distributor

(2) = the humidifier is connected to two distributors (using the "Y" kit: UEKY000000) or UEKY000400)

2 = the humidifier is fitted with two outlets and can be connected to two linear distributors

(4) = the humidifier is fitted with two outlets and can be connected to up to four linear distributors (using two "Y" kits)

\* = use CAREL "Y" kit code UEKY000000 (40 mm inlet and 2 x 30 mm outlets)

\*\* = use CAREL "Y" kit code UEKY40400 (40 mm inlet and 2 x 30 mm outlets)



# CAREL

**CAREL S.p.A.**

Via dell'Industria, 11 - 35020 Brugine - Padova (Italy)

Tel. (+39) 049.9716611 - Fax (+39) 049.9716600

e-mail: [carel@carel.com](mailto:carel@carel.com) - [www.carel.com](http://www.carel.com)

*Agenzia / Agency:*